

TAPE AND REEL (OSCILLATOR)

Surface Mount Miniature Quartz Crystal Oscillator

Reference: EIA-481

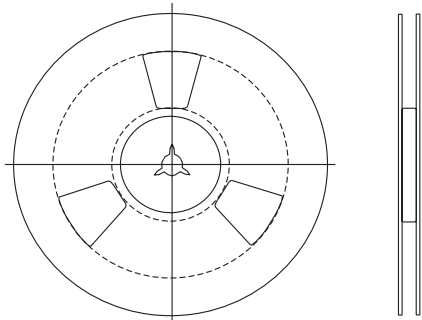

7" Reels
or
13" Reels

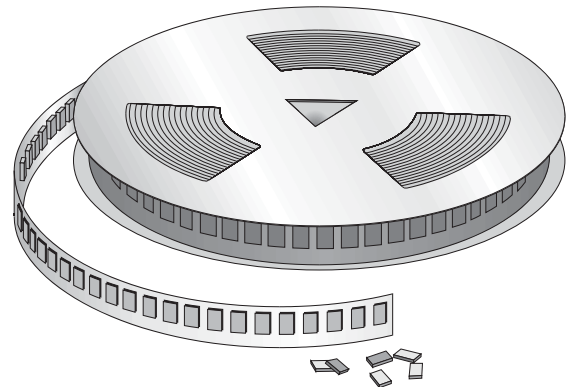

Notes:

1. Reel sketch is for reference only.
2. The center hole (hub hole) diameter is per EIA-481 standard 13 mm size.

Carrier tape material: 3000 Black Conductive Polycarbonate

REEL SELECTION

Unless specified otherwise, the following reel sizes will be used for the quantities listed.

OSCILLATOR TYPE	MAX QUANTITIES PER REEL	
	180 mm (7 in.)	330 mm (13 in.)
CXOM	800	3000
CXO3M	800	3000
CXO	500	2000
LSC	500	2000
LSM	500	2000
HGXO	800	3000
CXOX	3000	12000

OSCILLATOR ORIENTATION IN TAPE CAVITY - See pin 1 locator (▼)

Top View

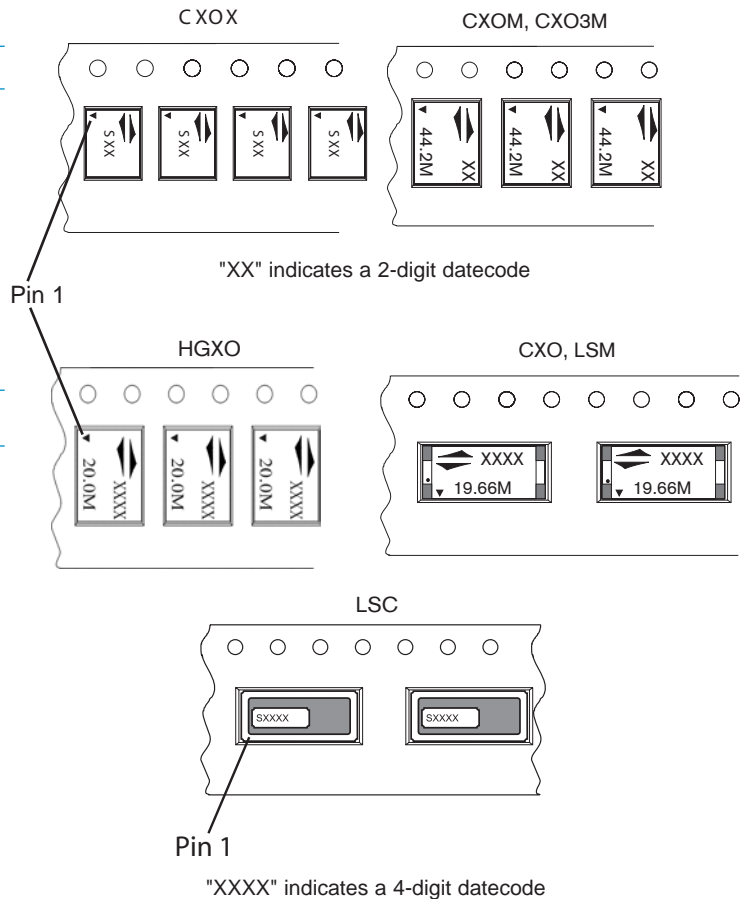

PART TO PART INDEXING P₁ AND A₀ & B₀ DIMENSIONS

Dimensions are in millimeters.	P ₁	A ₀	B ₀	Tape Width
CXOM	8.0	5.4	6.9	16
CXO3M	8.0	5.4	6.9	16
CXO	16.0	10.6	5.1	16
LSC	16.0	10.6	5.1	16
LSM	16.0	10.6	5.1	16
HGXO	8.0	5.6	7.7	16
CXOX	4.0	2.9	3.6	12

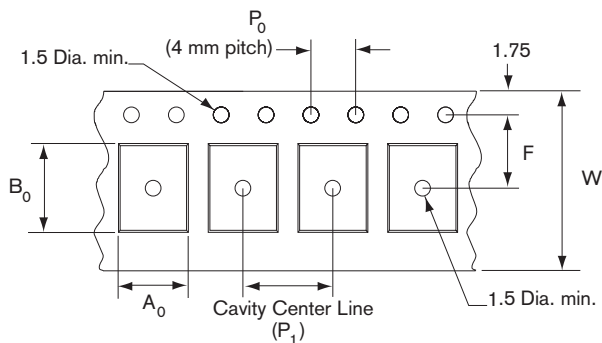

For 16 mm tape width, W = 16, F = 7.5

For 12 mm tape width, W = 12, F = 5.5

