





Coolant inlet and outlet are marked with symbols: Inlet: ; Outlet: 

CAUTION: READ MANUAL BEFORE OPERATING COOLING UNIT

- Input power must be rated for 230 VAC at 50 or 60 Hz
- Use water or water/glycol as coolant
- Run cooling unit at correct coolant level, otherwise cooling capacity will be reduced
- Use cooling hoses that can handle max pressure of liquid circuit and are resistant to corrosion from coolant
- Never operate cooling unit if it is damaged or leaking
- Before starting any service work on cooling unit, disconnect it from main power source

global solutions: local support™

Americas: +1.888.246.9050

Europe: +46.31.704.67.57

Asia: +86.755.2714.1166

WL 1500

Liquid Cooling System

USER MANUAL

TABLE OF CONTENTS

	Pg No.
1 Description	2
2 Technical Data	3
2.1 Physical Dimensions	3
2.2 Performance Data	3
2.3 Environmental Specifications	3
2.4 Settings	3
3 Operational Settings	4
4 Settings	5
4.1 Maximum Pressure	5
4.2 Maximum Flow Rate	5
5 Maintenance	6
5.1 Heat Exchanger	6
5.2 Water Filter	6
6 Placing Out of Operation	7
7 Spare Parts List and Illustration	8
8 Liquid and Electronic Schematic	9

1 DESCRIPTION

The WL 1500 cooling unit is intended to remove heat from a liquid circuit. The coolant can be either water or a mixture of water and water-glycol (antifreeze). Water circulates in a closed loop between the ambient cooling system and a cold plate at the heat source. Heat is removed from the water by an air-cooled heat exchanger. The capacity of the cooling unit is dependent on the temperature differential, which is defined as the difference between the ambient temperature and the water outlet temperature. The cooling unit is designed to remove 1500 W of heat at a temperature differential of 12°C. The maximum forward pressure is limited by a bypass valve. Cooling hoses supplied by user are connected to threaded nozzle that can accommodate a 9 mm hose ID.

2 TECHNICAL DATA

2.1 PHYSICAL DIMENSIONS

- Length: 479 mm
- Width: 398 mm
- Height: 481 mm
- Weight: 38.5 kg without filling
- Coolant capacity: 3 L

2.2 PERFORMANCE DATA

- Cooling capacity: 1500 W
- Flow rate: > 4.0 l/min at 4 bar
- Mains voltage: 230 VAC at 50/60 Hz
- Current consumption: 2.5 A
- Noise level: ≤ 68 dB(A) distance 1 m in any direction

2.3 ENVIRONMENTAL SPECIFICATIONS

- Ambient temperature: +5°C to +40°C
- Storage temperature: -25°C to +70°C (storage without water)
- Air humidity: 20% to 80%

2.4 SETTINGS

- Maximum forward pressure: 6 bar

3 OPERATIONAL SETTINGS

1. Position the cooling unit horizontally and keep obstructions away from the air inlet to allow for sufficient air circulation.
2. Remove the service cover.
3. Insert the cable and connect the cable to the terminals according to the terminal diagram; use a 3 mm screwdriver to connect the wires to the terminal block.
4. Close the service cover.
5. Connect the external hoses to the cooling unit.
6. Open the lid of the heat exchanger.
7. Fill the cooling unit with approximately 3 L of coolant.

Note: The coolant level must be above the fins in order to maintain peak cooling performance, otherwise the cooling capacity will be reduced.

8. Allow the cooling unit to run for 10 minutes and deaerate the liquid circuit.
9. Check the coolant level and refill if necessary.
10. Close the lid.



4 SETTINGS**4.1 MAXIMUM PRESSURE**

The maximum pressure has been adjusted at the factory according to specifications (at 60 Hz). If it is necessary to change this setting, then perform the following steps:

1. Disconnect the cooling unit from the main power source.
2. Remove the entire cover of the cooling unit.
3. Increase the maximum pressure by turning the setscrew clockwise; or reduce maximum pressure by turning the setscrew counter clockwise.

4.2 MAXIMUM FLOW RATE

Under low pressure loss conditions, the pump provides a water flow rate of more than 6 lpm. If it is necessary to reduce this flow, then close the ball cock until the desired flow rate is set.

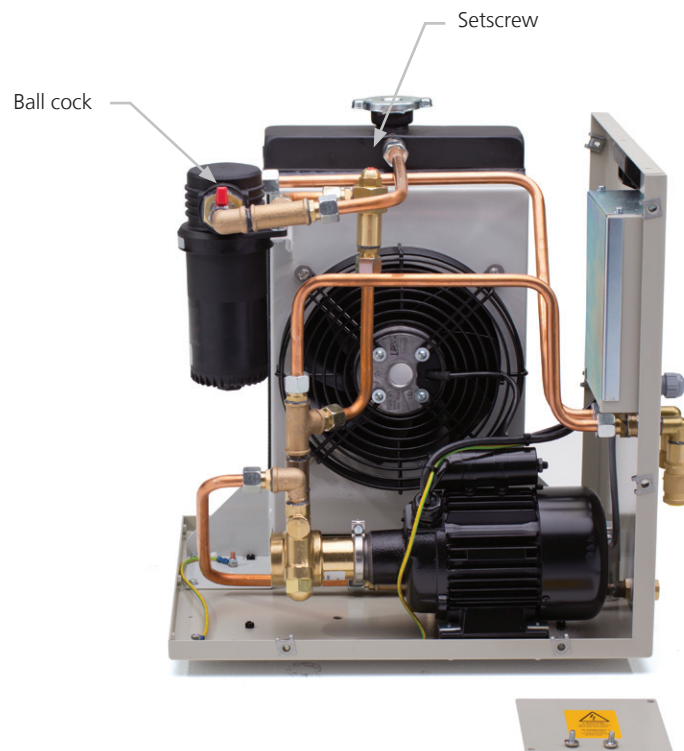

5 MAINTENANCE

Regularly check the coolant level and refill as necessary.

5.1 HEAT EXCHANGER

In order to achieve maximum cooling capacity, the heat exchanger of the cooling unit must be kept clean. The cooling unit is equipped with an air filter that can easily be changed. It should be checked periodically and if necessary, replaced.

Replacement procedure is as follows:

1. Disconnect the cooling unit from the main power source.
2. Remove the side cover.
3. Remove the old filter and replace with a new filter. Also, check the heat exchanger for cleanliness. If debris is on the surface of the fins, then clean the fins with high pressure air or a damp cloth.
4. Mount the side cover.

5.2 COOLANT FILTER

Regularly check the coolant filter for cleanliness, as this will cause reduced coolant flow over time.

Note: If the coolant filter is blocked, the pressure rises and the bypass valve opens.

Replacement procedure is as follows:

1. Disconnect the cooling unit from the main power source.
2. Remove the side cover.
3. Close the ball cock.
4. Unscrew the coolant filter.
Note: Some coolant will run out of the filter. Collect the coolant in a suitable container.
5. Replace the filter and mount the back onto the liquid circuit.
6. Open the ball cock.
7. Mount the side cover.
8. Run the cooling unit to deaerate the liquid circuit for 10 minutes.
9. Check the coolant level and refill if necessary.

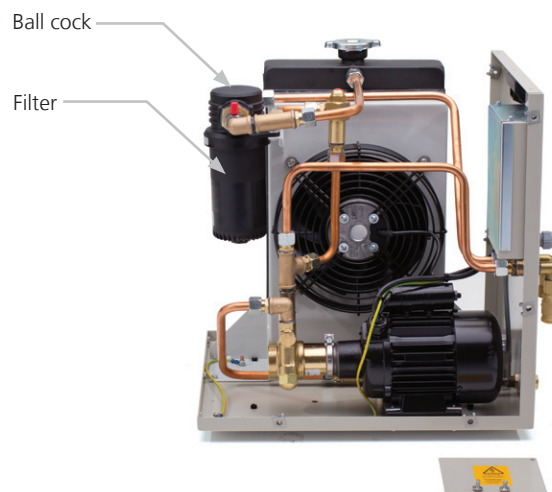

WL 1500

Liquid Cooling System

USER MANUAL

6 PLACING OUT OF OPERATION

1. Disconnect the cooling unit from the main power source.
2. Remove the electrical connections.
3. Remove the hoses from the cooling unit.
4. Remove the cap and drain the coolant in a container.
5. Mount the cap on the drain.



WL 1500

Liquid Cooling System

USER MANUAL

7 SPARE PARTS LIST AND ILLUSTRATIONS

NO.	DESCRIPTION	CODE NUMBER
1	Cap	91729015
2	Fan	95251637
3	Sealing for cap, 15, 6x2	93300405
4	Pump	95205221
5	Filter	95109956
6	Lid	95179902
7	Air filter*	95189501
8	Capacitor for fan	95290701

*Filter not shown



8 LIQUID AND ELECTRONIC SCHEMATIC

LIQUID CIRCUIT DIAGRAM

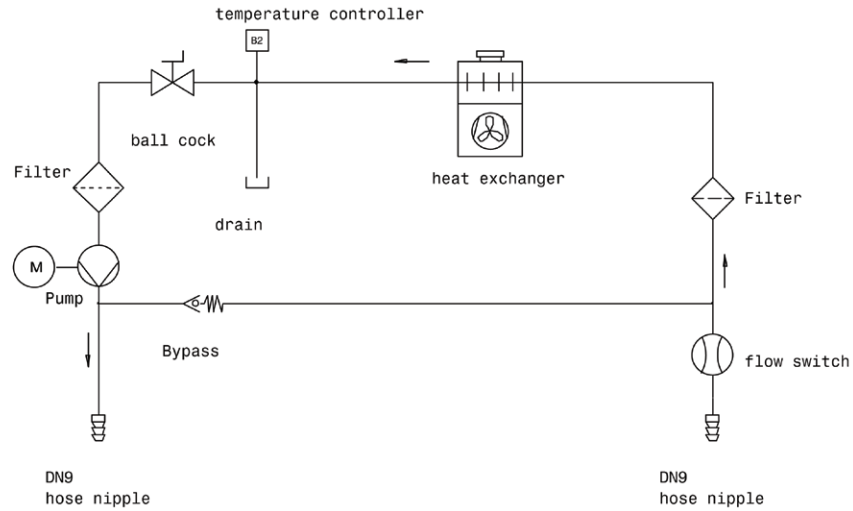

ELECTRONIC SCHEMATIC

Current Schematic

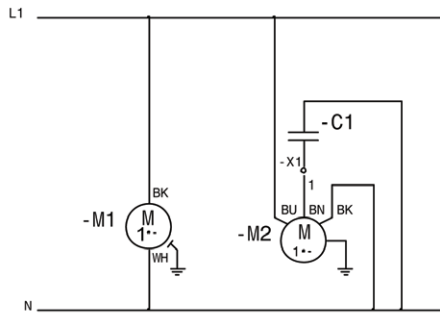

Terminal Schematic

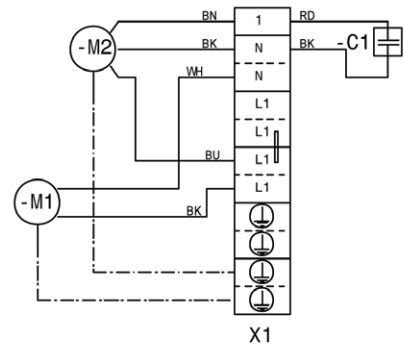

Legend

- C1** capacitor
- M1** pump
- M2** fan

THR-UM-WL-1500 0912

Any information furnished by Laird Technologies, Inc. and its agents is believed to be accurate and reliable. All specifications are subject to change without notice. Responsibility for the use and application of Laird Technologies materials rests with the end user. Laird Technologies makes no warranties as to the fitness, merchantability, suitability or non-infringement of any Laird Technologies materials or products for any specific or general uses. Laird Technologies shall not be liable for incidental or consequential damages of any kind. All Laird Technologies products are sold pursuant to the Laird Technologies Terms and Conditions of sale in effect from time to time, a copy of which will be furnished upon request. © Copyright 2011 Laird Technologies, Inc. All Rights Reserved. Laird, Laird Technologies, the Laird Technologies Logo, and other marks are trade marks or registered trade marks of Laird Technologies, Inc. or an affiliate company thereof. Other product or service names may be the property of third parties. Nothing herein provides a license under any Laird Technologies or any third party intellectual property rights.