

### DESCRIPTION

The CX1H quartz crystal is a high quality tuning fork resonator for use in Series (two cascaded inverters) oscillators. The CX1H is hermetically sealed in a rugged, miniature ceramic package, one-fourth the size of an eight-pin mini-DIP. The CX1H crystal is manufactured using the STATEK-developed photolithographic process, and was designed utilizing the experience acquired by producing millions of crystals for industrial, commercial, military and medical applications.

### FEATURES

- Miniature tuning fork design
- High shock resistance
- Designed for low power applications
- Compatible with hybrid or PC board packaging
- Low aging
- Full military testing available
- Designed and manufactured in the USA

### PACKAGE HANDLING

The CX crystal is hermetically sealed in a ceramic package. Normal handling and soldering precautions for small, low thermal mass parts are adequate when installing or testing CX crystals. CX crystals may be wave soldered, with proper precaution taken to avoid desoldering the leads. A slow machine rate or too high a pre-heat temperature or solder bath temperature can damage the crystals. **Lead to package solder interface temperature should not exceed 175°C, glass lid to package seal rim temperature should not exceed 210°C.** If the seal rim reaches temperatures above the maximum specified, the package may lose its hermeticity. Loss of hermeticity results in a frequency decrease and motional resistance increase.

### EQUIVALENT CIRCUIT

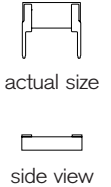
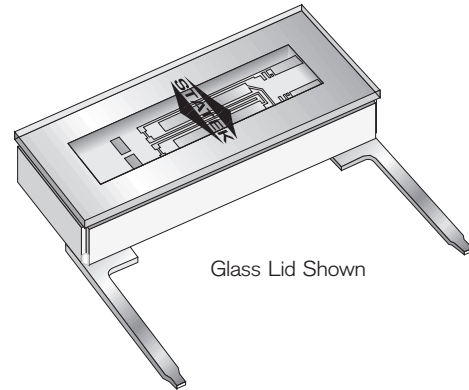
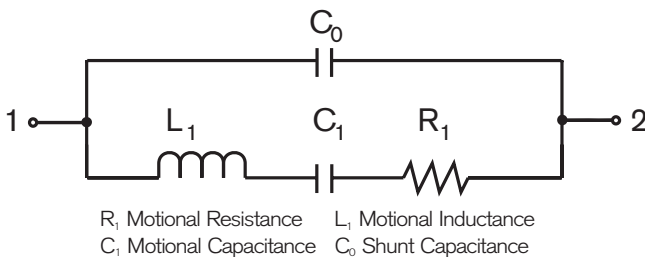

### PACKAGE DIMENSIONS

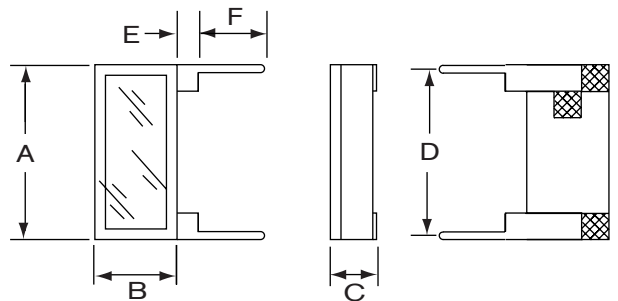

DIM	TYP.		MAX.	
	INCHES	mm	INCHES	mm
A	0.315	8.00	0.330	8.38
B	0.140	3.56	0.155	3.94
C	0.070	1.78	0.080	2.03
D	0.300	7.62	0.310	7.87
E	0.020	0.51	0.040	1.02
F	0.150	3.81	0.160	4.06

Leads 0.013" x 0.018" (0.33 x 0.46 mm) typical.

### CONVENTIONAL SERIES OSCILLATOR CIRCUIT

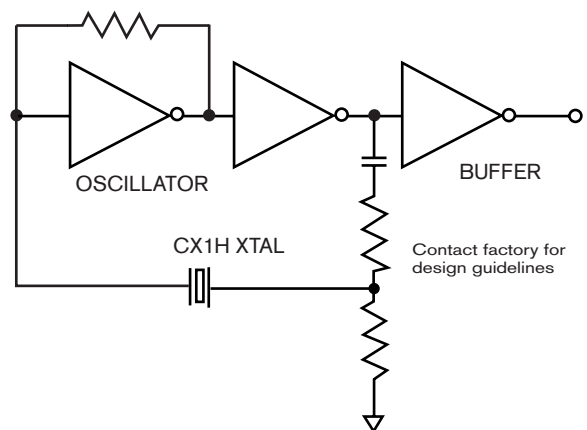

## SPECIFICATIONS

Specifications are typical at 25°C unless otherwise noted.  
Specifications are subject to change without notice.

Frequency Range	10 kHz to 600 kHz
Calibration Tolerance <sup>1</sup>	(see below)
Motional Resistance (R <sub>1</sub> )	Figure 1 MAX.: 2x Typ. @ 10-169.9 kHz 2.5x Typ. @ 170-600 kHz
Motional Capacitance (C <sub>1</sub> )	Figure 2
Quality Factor (Q)	Figure 3 Min. is 0.25x Typ.
Shunt Capacitance (C <sub>0</sub> )	2.0 pF MAX
Drive Level	1.5 μW MAX. @ 10-24.9 kHz 3.0 μW MAX. @ 25-600 kHz
Turning Point (T <sub>0</sub> ) <sup>2</sup>	Figure 4
Temperature Coefficient (k)	-0.035 ppm/°C <sup>2</sup>
Aging, first year	5ppm MAX.
Shock, survival <sup>3</sup>	1,000 G peak 1ms, 1/2 sine
Vibration, survival <sup>3</sup>	20 G RMS 10-2,000 Hz
Operating Temperature	-10°C to +70°C (Commercial) -40°C to +85°C (Industrial) -55°C to +125°C (Military)
Storage Temperature	-55°C to +125°C
Max Process Temperature	See package handling

1. Higher frequency calibration available.
2. Other turning point available.
3. Higher shock and vibration available.

### CX1H Standard Calibration Tolerance at 25°C

Frequency Range (kHz)			
10-74.9	75-169.9	170-249.9	250-600
± 30 ppm	± 50 ppm	±100 ppm	±200 ppm

### HOW TO ORDER CX1H LEADED CRYSTALS

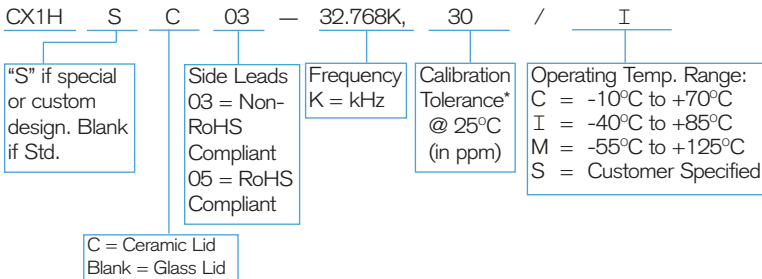

\*The above table provides the best calibration tolerance available for each frequency range at 25°C.

FIGURE 1  
CX1H TYPICAL MOTIONAL RESISTANCE (R<sub>1</sub>)

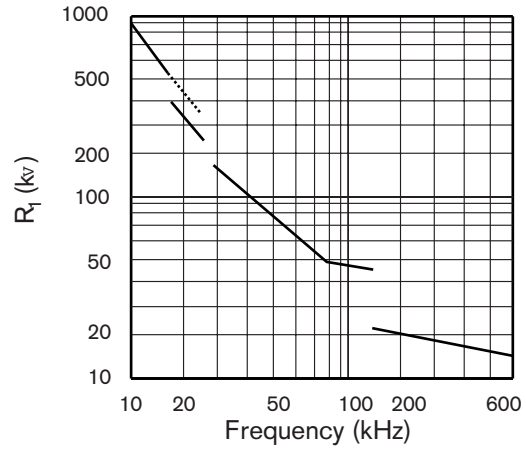

FIGURE 2  
CX1H TYPICAL MOTIONAL CAPACITANCE (C<sub>1</sub>)

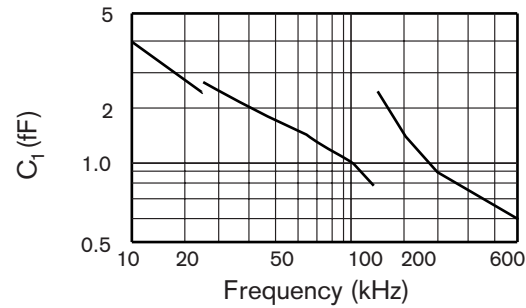

FIGURE 3  
CX1H TYPICAL QUALITY FACTOR (Q)

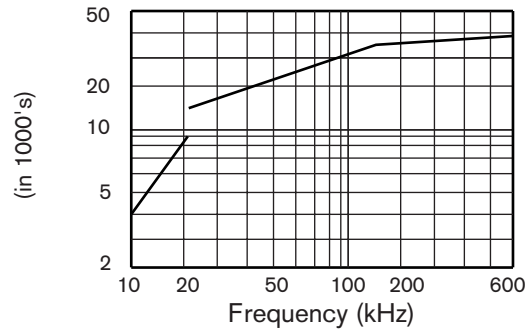
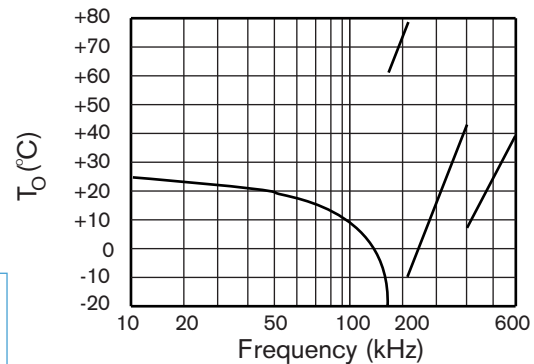

FIGURE 4  
CX1H TYPICAL TURNING POINT TEMP. (T<sub>0</sub>)



Note: Frequency (f) deviation from frequency (f<sub>0</sub>) @ turning point temperature (T<sub>0</sub>):

$$\frac{f-f_0}{f_0} = k(T-T_0)^2$$

### PACKAGING FOR LEADED CRYSTALS

CX1H - Tray Pack (Standard)