



CX-2 CRYSTAL

9.6 MHz to 160 MHz
Miniature AT-Cut Crystal

Fundamental Mode: 9.6 MHz - 70 MHz
Third Overtone Mode: 70 MHz - 160 MHz

DESCRIPTION

The CX-2 AT-cut quartz crystal is a high quality AT-cut resonator. The CX-2 is hermetically sealed in a rugged, miniature ceramic package, and available in several lead configurations. The CX-2 crystal is manufactured using the STATEK-developed photolithographic process, and was designed utilizing the experience acquired by producing millions of crystals for industrial, commercial, military and medical applications.

FEATURES

- Low profile hermetically sealed ceramic package
- Excellent aging characteristics
- Available with glass or ceramic lid
- High shock and vibration resistance
- Custom designs available
- Full military testing available
- Designed and manufactured in the USA

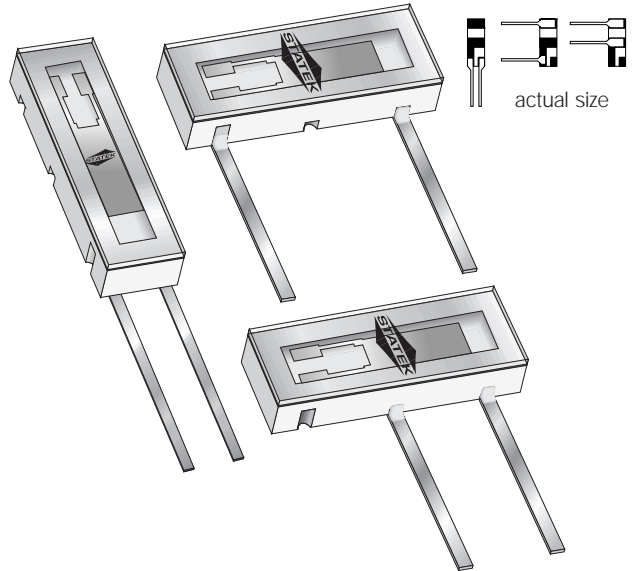

PACKAGE DIMENSIONS

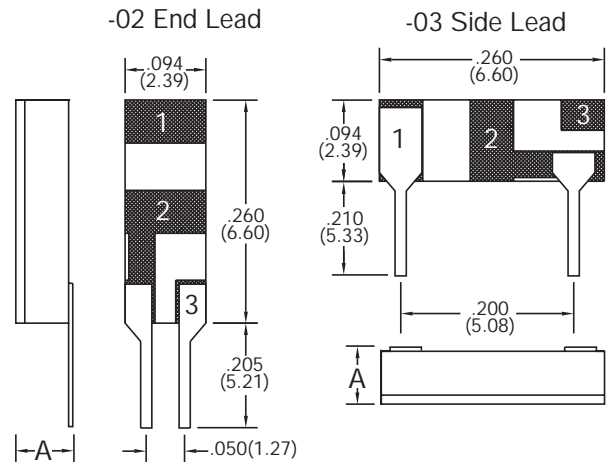

INCHES (mm)

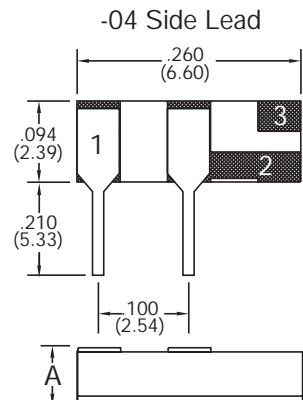

Notes:

1. Terminal 1 is electrically connected internally to terminal 3.
2. Lead dimensions
Width: .013" (.33mm) Typical
Thickness: .007" (.18mm) Typical
3. A = Glass Lid .080 (2.03) max.
Ceramic Lid .095 (2.41) max.

EQUIVALENT CIRCUIT

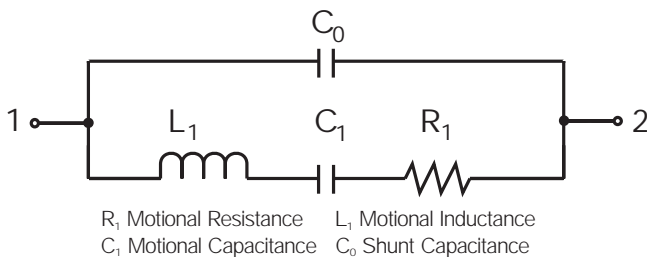

SPECIFICATIONS

Specifications are typical at 25°C unless otherwise noted.
Specifications are subject to change without notice.

	10 MHz	32MHz	155.52 MHz
Motional Resistance R_1 (Ω)	60	20	50
Motional Capacitance C_1 (fF)	2.8	7.8	0.5
Quality Factor Q (k)	95	36	41
Shunt Capacitance C_0 (pF)	1.4	2.4	3.2
Calibration Tolerance*	A $\pm 0.01\%$ (± 100 ppm)		
	B $\pm 0.1\%$		
	C $\pm 1.0\%$		
Load Capacitance	20 pF (Unless specified by customer)		
Drive Level	500 μ W MAX.		
Frequency-Temperature Stability**	-10°C to +70°C from ± 10 ppm		
	-40°C to +85°C from ± 20 ppm		
	-55°C to +125°C from ± 30 ppm		
Aging, first year	5ppm MAX.		
Shock, survival***	3,000g, 0.2 msec., 1/2 sine		
Vibration, survival	20g rms, 10-2,000 Hz random		
Operating Temperature	-10°C to +70°C Commercial		
	-40°C to +85°C Industrial		
	-55°C to +125°C Military		
Storage Temperature	-55°C to +125°C		
Max Process Temperature	See package handling		

Note: The characteristics of the frequency temperature stability follow that of AT cut thickness-shear mode.

* Tighter tolerances available as low as ± 5 ppm

** Does not include calibration tolerance

*** Higher shock version available

PACKAGE HANDLING

The CX crystal is hermetically sealed in a ceramic package. Normal handling and soldering precautions for small, low thermal mass parts are adequate when installing or testing CX crystals. CX crystals may be wave soldered, with proper precaution taken to avoid desoldering the leads. A slow machine rate or too high a pre-heat temperature or solder bath temperature can damage the crystals. **Lead to package solder interface temperature should not exceed 175°C, glass lid to package seal rim temperature should not exceed 210°C.** If the seal rim reaches temperatures above the maximum specified, the package may lose its hermeticity. Loss of hermeticity results in a frequency decrease and motional resistance increase.

PACKAGING

CX-2-Leaded -Tray Pack (Standard)

CONVENTIONAL CMOS PIERCE OSCILLATOR CIRCUIT

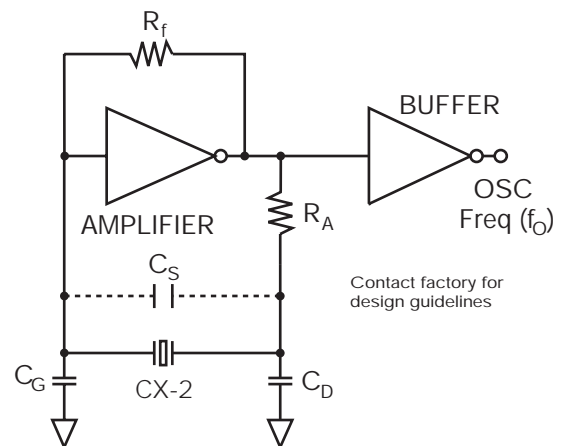

HOW TO ORDER CX-2 LEADED CRYSTALS

CX-2			-03	32 MHz	(25ppm	/	25ppm	/	50ppm	/)
"S" if special or custom design. Blank if Std.	O.T.=3 RD O.T. Mode Blank=Fundamental Mode	C=Ceramic Lid Blank=Glass Lid	Leads -02 -03 -04	Frequency	Calibration Tolerance* @25°C (A) (B) (C)	Frequency Stability over Temp. Range	Total Frequency Tolerance	Temp. Range: C = Commercial I = Industrial M = Military S = Specify					

*Other calibrations fill in ppm.

10140 - Rev C