

SPECIFICATIONS

CONTACT RATING: Dependent upon contact material See Page 28.

MECHANICAL LIFE: 30,000 make-and-break cycles.

CONTACT RESISTANCE: 20 mΩ max. initial @ 2-4VDC
100mA for both silver and gold plated contacts.

INSULATION RESISTANCE: 1,000 MΩ min.

DIELECTRIC STRENGTH: 1,000 Vrms min. @sea level.

OPERATING TEMPERATURE: -30°C to 85°C.

MATERIALS

CASE: Diallyl phthalate (DAP) (UL94v-0).

ACTUATOR: Brass, chrome plated.

BUSHING: Brass or zinc, nickel plated.

HOUSING: Stainless Steel.

SWITCH SUPPORT: Brass,tin plated.

TERMINAL/CONTACT: Brass,with Silver or gold plated.

(See Page 28)



HOW TO ORDER

MODEL NO. ACTUATOR BUSHING TERMINATIONS CONTACT MATERIAL SEAL RoHS SOLDERING

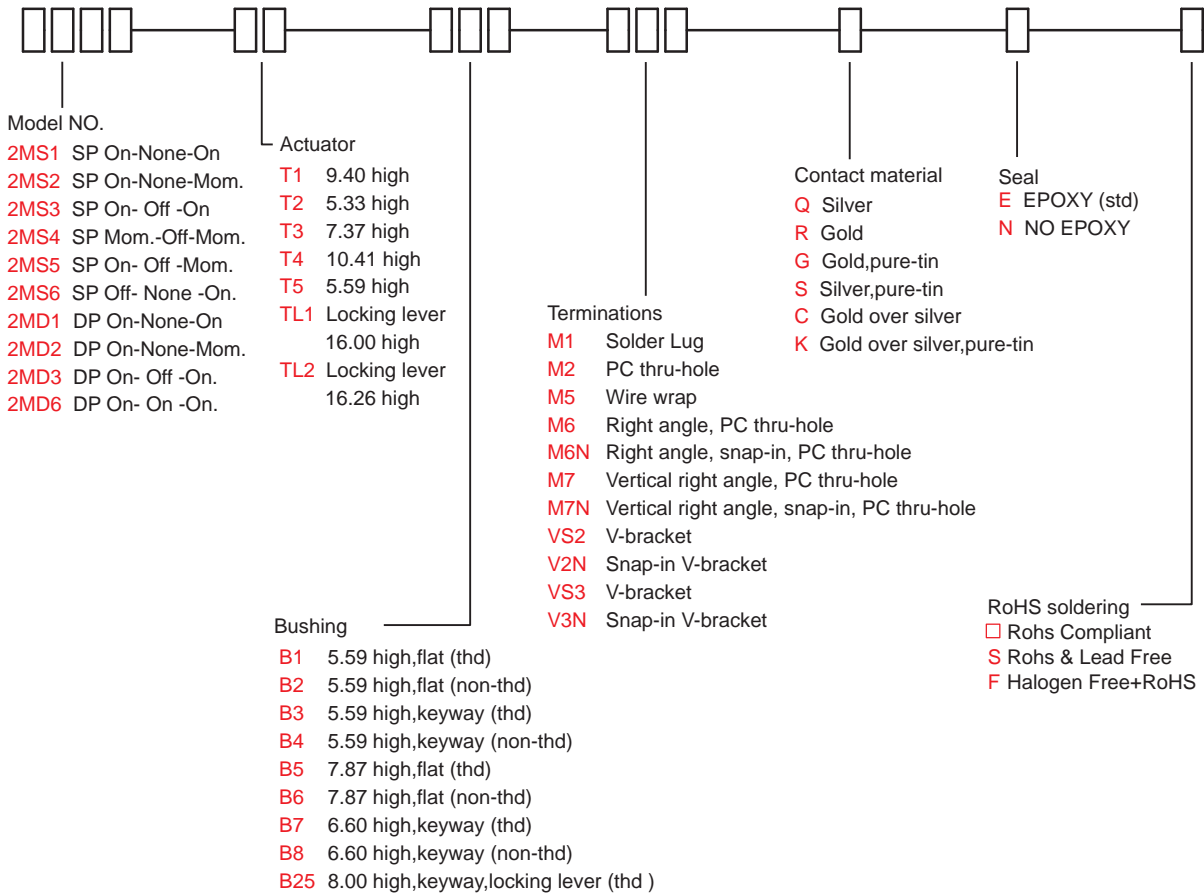

SWITCH FUNCTION



2M Sub-Minature Toggle Switches

NO. POLES	UL/CSA MODEL NO.	MODEL NO.	SWITCH FUNCTION			CONNECTED TERMINALS / SCHEMATIC		
			POS.1	POS.2	POS.3	POS.1	POS.2	POS.3
SP	Q2211	2MS1	ON	NONE	ON	2-3	N/A	2-1
	Q2212	2MS2	ON	NONE	MOM			
	Q2213	2MS3	ON	OFF	ON		OPEN	
	Q2214	2MS4	MOM	OFF	MOM			
	Q2215	2MS5	ON	OFF	MOM	OPEN	N/A	3-1
	Q2216	2MS6	OFF	NONE	ON			
DP	Q2221	2MD1	ON	NONE	ON	2-3,5-6	N/A	2-1,5-4
	Q2222	2MD2	ON	NONE	MOM			
	Q2223	2MD3	ON	OFF	ON		OPEN	
	Q2226	2MD6	ON	ON	ON			

MOM=MOMENTARY

▲ Please check the availability in advance before order

POLE OPTIONS

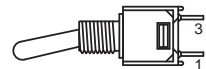
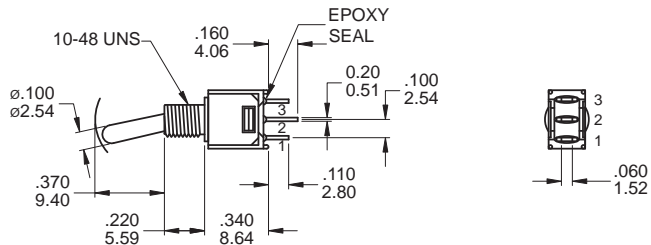
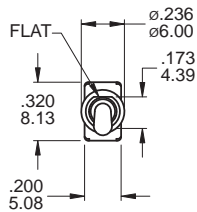

SPDT

2MS6 Models : Omit 2nd terminal

Part No. Shown : 2MS1T1B1M1QE

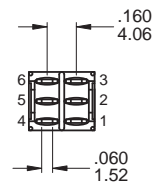
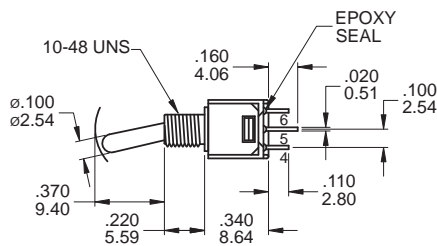
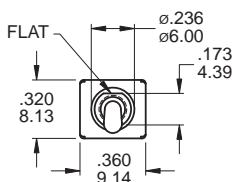

DPDT

Part No. Shown : 2MD1T1B1M1RE

ACTUATOR OPTIONS

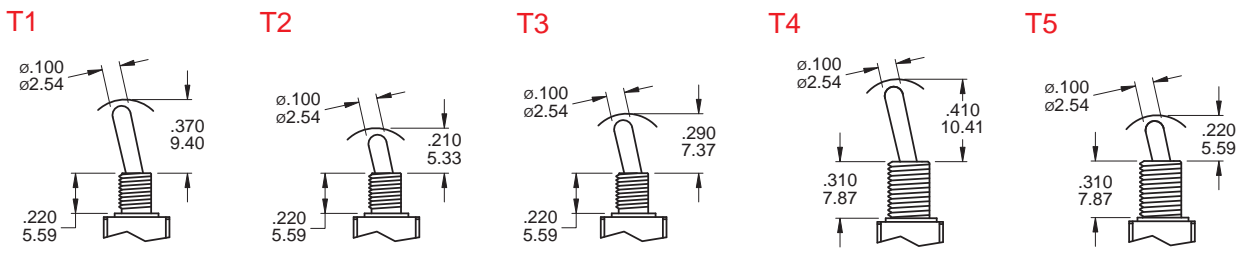

NONE: T1,T2,T3 Actuator shown with B1 to B4 bushing, subtract 0.09 (2.29) for B5 bushing, subtract 0.04 (1.02) for B7 bushing.
 T4,T5 Actuator shown with B5,B6 bushing, add 0.09 (2.29) for B1 to B3 bushing, add 0.05 (1.27) for B7 bushing.
 Std for M1,M2 Terminal sub .016(.040) for M6,M7,VSX

2M
Toggle Switches

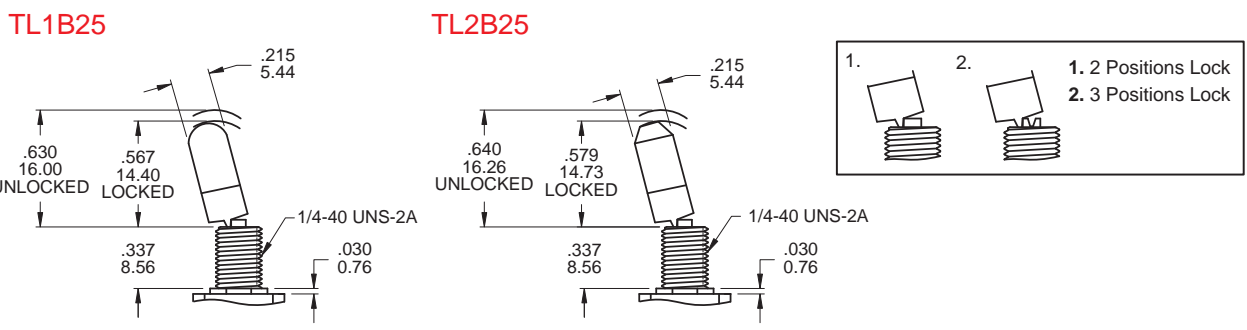

BUSHING OPTIONS

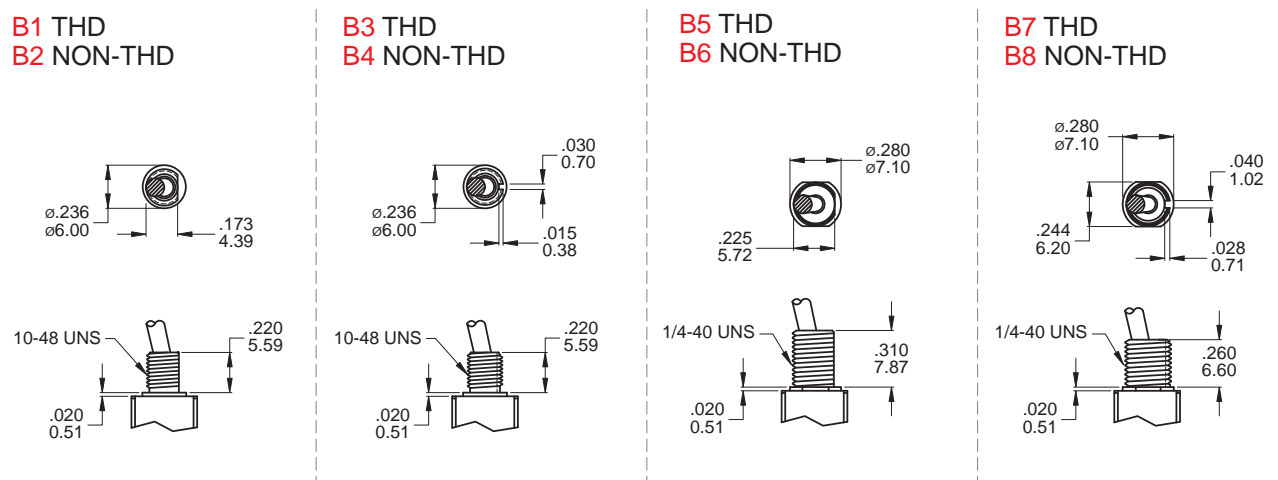

TERMINATION OPTIONS

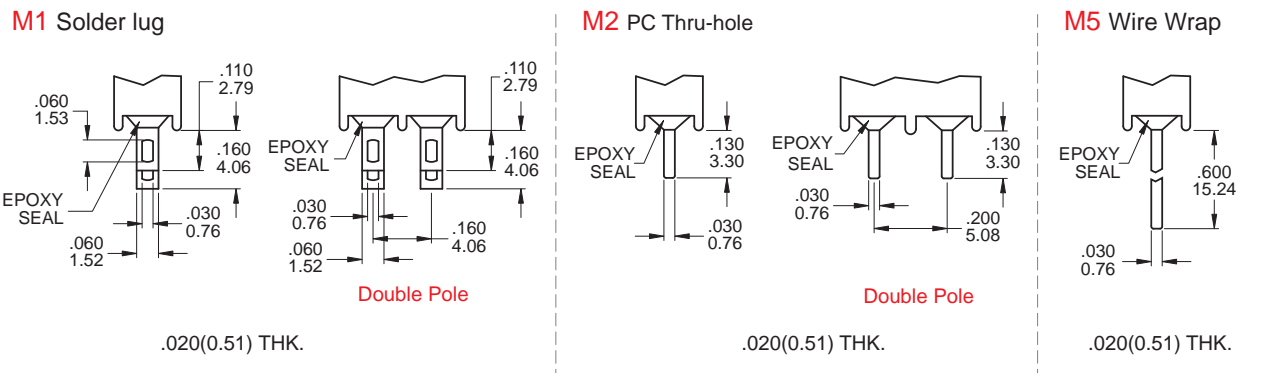



M6

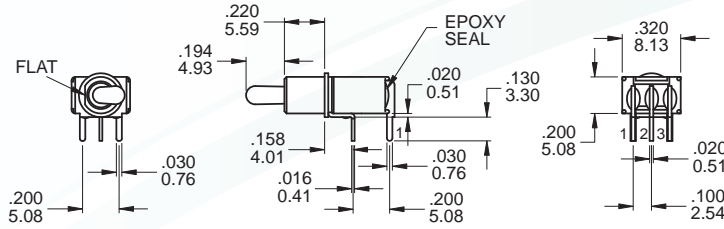

P.C. MOUNTING

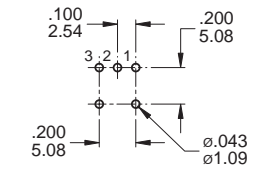

SPDT

Part No. Shown : 2MS1T2B2M6RE

M6

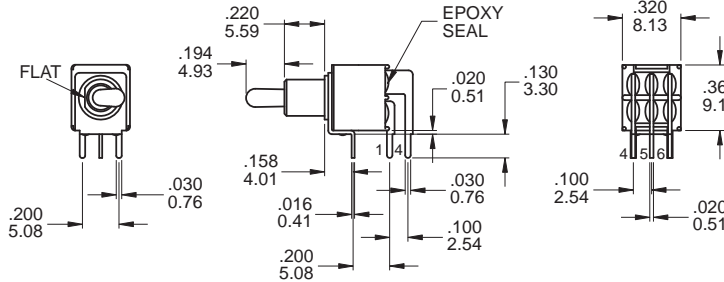

P.C. MOUNTING

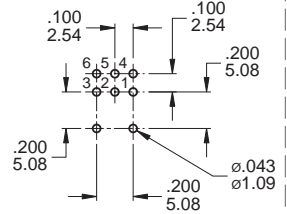

DPDT

Part No. Shown : 2MD1T2B2M6QE

M7

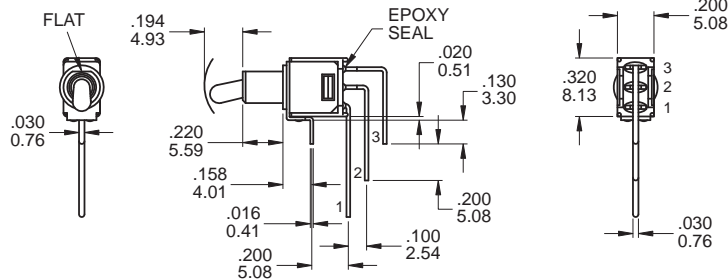

P.C. MOUNTING

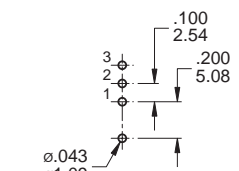

SPDT

Part No. Shown : 2MS1T2B2M7RE

M7

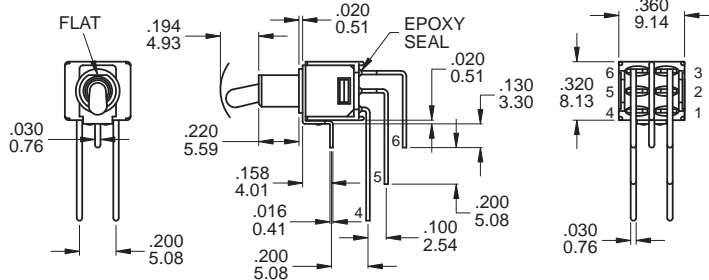
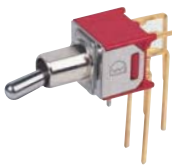

P.C. MOUNTING

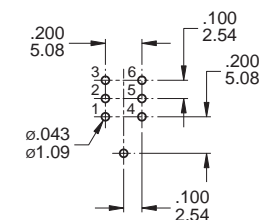

DPDT

Part No. Shown : 2MD1T2B2M7RE

VS2 - VS3

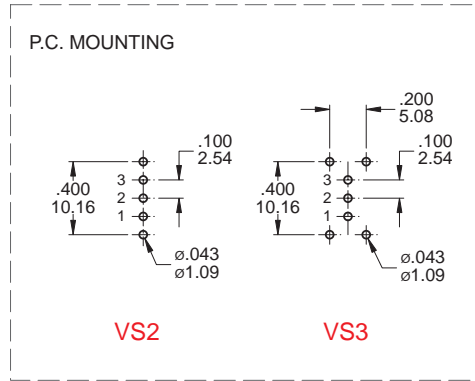
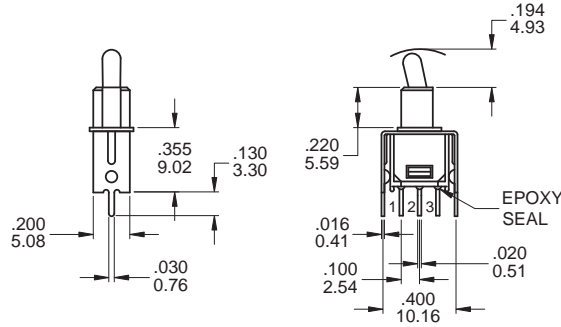

SPDT

Part No. Shown : 2MS1T2B2VS2QE

VS2 - VS3

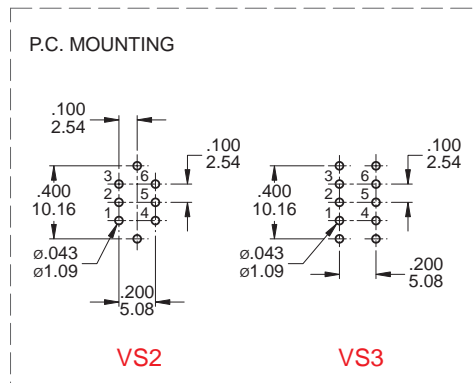
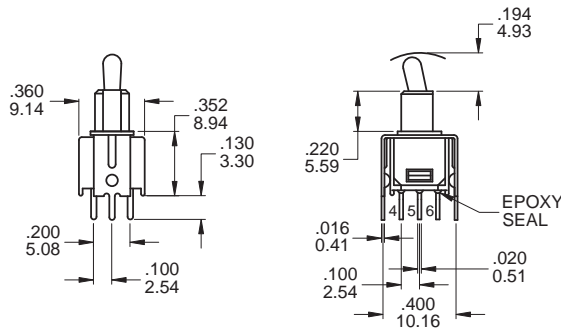

DPDT

Part No. Shown : 2MD1T2B2VS2QE

SNAP-IN TERMINATION OPTIONS

M6N

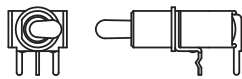

M7N

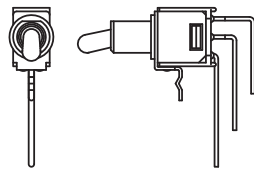

V2N

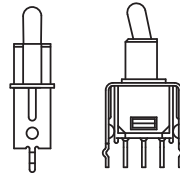

V3N

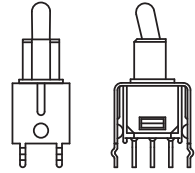

PANEL MOUNTING

10-48 BUSHING

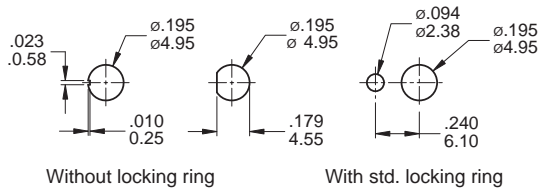

1/4 IN. BUSHING

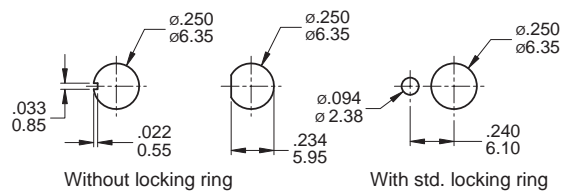

HARDWARE

10-48 NUT

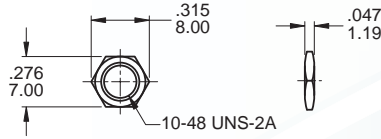

MNU-2M01

Supplied standard with
B1/ B3 bushing

LOCK WASHER

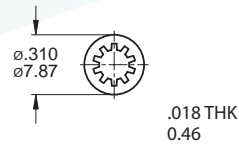

MNU-2M03

Supplied standard with
B1 / B3 bushing

CONTACT MATERIAL OPTIONS

	CONTACT PLATING	TERMINAL PLATING	RATINGS
Q	Silver	Q = Silver	3 Amps with resistant load @ 120VAC or 28VDC 1 Amps with resistant load @ 250VAC
S		S = Silver,pure - tin	
C	Gold over Silver	C = Gold over silver	
K		K = Gold over silver,pure - tin	
R	Gold	R = Gold	0.4 Volt - Amps (VA) max. @ 20V max. (AC or DC)
G		G = Gold,pure - tin	

SOLDERING PROCESSES

MANUAL SOLDERING: Use soldering iron of 30 watts, controlled at 350°C approximately 5 seconds while applying solder.

WAVE SOLDERING: Recommended Soldering Temperature: 260 ± 5°C

Duration of Solder Immersion: Max 5 sec. (PCB is 1.6mm in thickness)