

NOTE :

1. ALL DIMENSIONS ARE IN MILLIMETERS . BRACKETED DIMENSIONS ARE IN INCHS .INCHS.
2. GENERAL TOLERANCE : 50.2 mm
3. MATERIAL : SEE PAGE 3 OF 3.

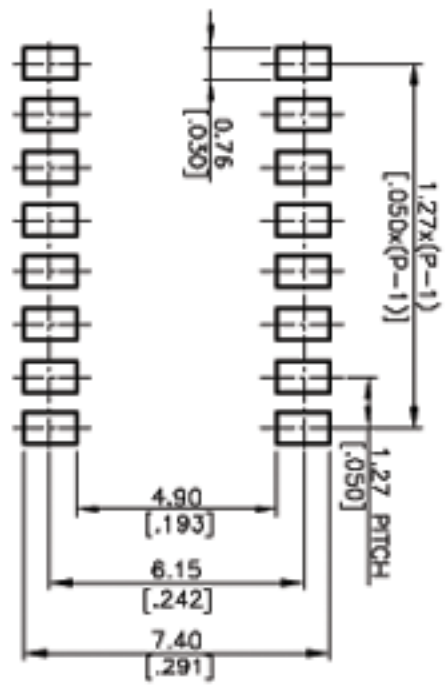

NHDS-02-V	2	3.77 [1.148]
NHDS-04-V	4	6.31 [2.48]
NHDS-06-V	6	8.85 [3.48]
NHDS-08-V	8	11.39 [4.48]
NHDS-10-V	10	13.93 [5.48]
PROD.NO.	NO. OF POS	DIM A

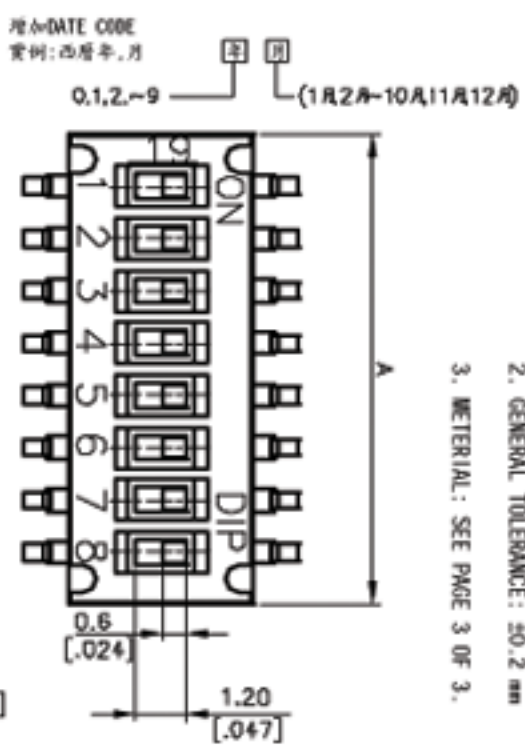
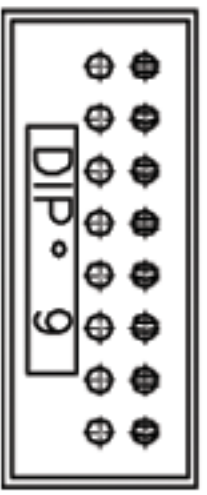
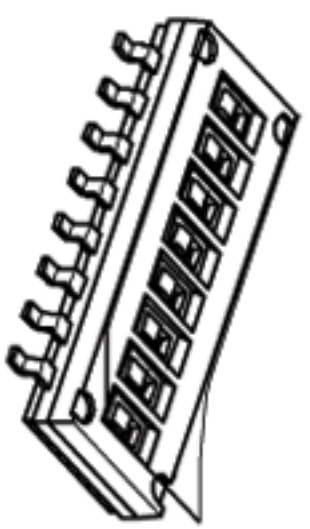
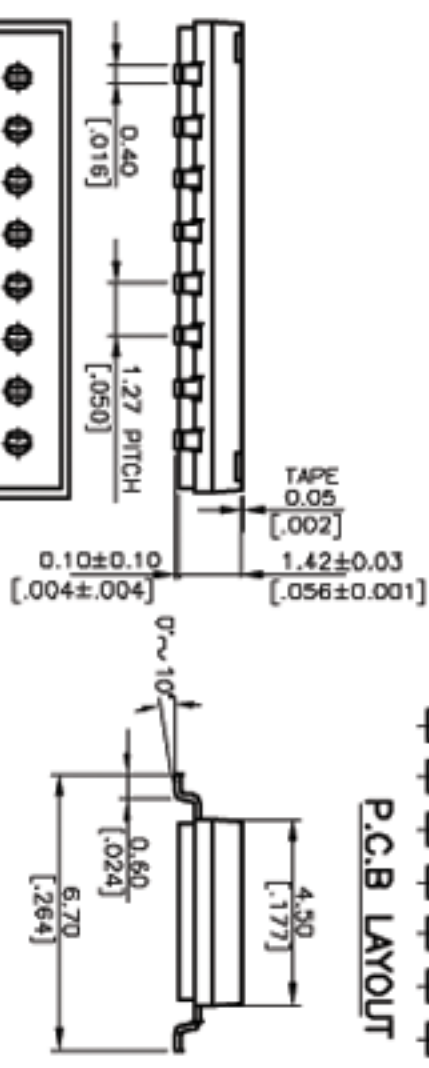

NHDS	UT	電子技術部	李國強
NHDS	A	電子部	李國強
NHDS		技術部	李國強
FILE NO.			

符號	原尺寸	修改後尺寸	變更日期
1 (A)			
2 (B)			
3 (C)			
4 (D)			
5 (E)			

SCALE (比例) : 4 : 1

TOLERANCE (公差) :
0.00 mm ± 0.25mm
0.0 mm ± 0.40mm

FILE NAME : Y06888

TITLE 圖名	S.M.T. TYPE HALF PITCH (1.6mm)		SIZE 圖紙	A4
DWG NO. 圖號	NHDS SERIES		UNIT 單位	inch mm
REV. 版本	A	DATE 日期	JUL - 17 - 2008	SHEET 張數
CHECKED BY 審核	RICHARD		DRAWN BY 製圖	IRENE

德利威電子股份有限公司
DAILYWELL ELECTRONICS CO.,LTD.

ZITEM	DESC.	Q'TY	MATERIALS	TREATMENT	REMARK
1.	COVER	1	THERMOPLASTIC NYLON UL94V-0	MOLDED BLACK	-
2.	ACTUATOR		THERMOPLASTIC LCP	MOLDED WHITE	②
3.	CONTACT		ALLOY COPPER	GOLD PLATED	②
4.	TERMINAL		BRASS C2680-EH	GOLD	②
5.	BASE	1	THERMOPLASTIC NYLON UL94V-0	MOLEDE BLACK	-
6.	TAPE		KATPON	-	-

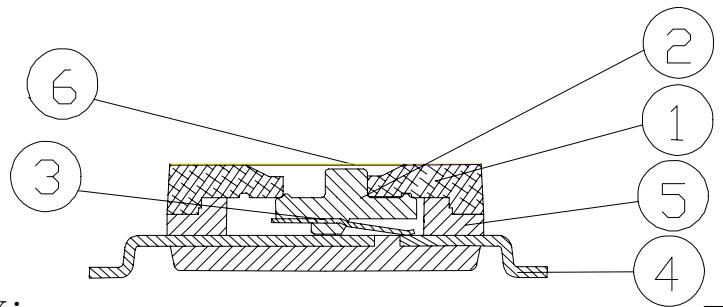

Remark:

① Prod. No. : (F)N H D S - □ □ □ - □ - V - □

FHDS TERMINAL LENGTH 8.1 mm

NHDS TERMINAL LENGTH 6.7 mm

Number Of Position: _____

- 02 = 2 Position
- 04 = 4 Position
- 06 = 6 Position
- 08 = 8 Position
- 10 = 10 Position

Package Style:

□ = Tube

T/R= Tape & Reel

V=Lead Free

Seal:

□=Regular

T =Top Tape Sealed

□ =in ON position

F =in OFF position

□ =Gold 3u" MIN

A =Gold 10u" MIN

A	DWG. REL.	邱明義
REV.	ECO. NO.	APPD.

TITLE:	APPD. : 邱明義
HALF PITCH DIP SWITCH	CHKD. : 邱明義
RROD. NO. : (F)NHDS-□□□-V	PR. : 楊佩儒
FILE NO. : E-V-CD11	REV : A SHEET : 1 of 1

(F)NHDS-V SPECIFICATION

FILE No. : E-V-AD09
REV. : B
Page : 1 / 4

1. Style:D

This specification describes "WASHABLE OF DUAL IN-LINE PACKAGE SWITCHES", mainly used as signal switch of electric devices, with the general requirements of mechanical and electrical characteristics.

1.1 Operating Temperature Range : -40°C~+85°C

1.2 Storage Temperature Range : -40°C~+85°C

2. Current Range:

2.1 Non-Switching: 100mA, 50V DC

2.2 Switching: 25mA, 24V DC

3. Type of Actuation: Actuated by sliding

4. Test Sequence:

MELECTRIC PERFORMANCE	ITEM	DESCRIPTION	TEST CONDITIONS	REQUIREMENTS
	1.	Visual Examination	By visual examination check without any out pressure & testing.	There shall be no defects that affect the serviceability of the product.
	2.	Contact Resistance	①To be measured between the two terminals associated with each switch pole. ②Measurements shall be made with a 1 kHz shall current contact resistance meter.	100mΩ max. (initial)
	3.	Insulation Resistance	500 V DC , 1 minute±5 sec.	100MΩ min
	4.	Dielectric withstanding Voltage	300 V AC (50Hz or 60 Hz) shall be applied between all the adjacent terminals and between the terminal and the frame for 1 minute.	There shall be no breakdown or flashover.
	5.	Capacitance	1MHz±10kHz	5 pF max.

(F)NHDS-V SPECIFICATION

FILE No. : E-V-AD09
 REV. : B
 Page : 2 / 4

MECHANICAL PERFORMANCE	6	Operation Force	<p>Applied in the direction of operation. ON→OFF OFF→ON</p>	500 gf max – (F)NHDS-V (4.9N max)	
	7	Stop Strength	(F)NHDS-V: 1 kgf is applied in the operating direction and pulling direction operated for a period of 15 seconds.	There shall be no sign of damage mechanically.	
	8	Soldering Heat Resistance	①Soldering Temperature :		①As shown in item 3~6 ②Contact Resistance: 2Ω max. (final-after test)
			PROD SERIES	SMT TYPE TERMINAL NHDS-V	
			TEMP	260±5°C	
TIME	5~10sce				
②Duration of Solder Immersion: 5±1seconds. ③Frequency of Solder Process: 1 times max. (PCB is 1.6 mm in thickness.)					
9	Vibration	Shall be vibrated in accordance with Method 201A of MIL-STD-202F ①Frequency: 10-55-10 Hz 1 min/cycle. ②Direction: 3 vertical directions including the direction of operation ③Test Time: 2 hours each direction.	①As shown in item 2~6 (Contact Resistance: 2Ω max.) (final-after test)		
10	Shock	Shall be shocked in accordance with Method 213B Condition A of MIL-STD-202F 1)Acceleration : 50G 2)Action Time : 11±1 m seconds 3)Testing Direction : 6 sides 4)Test cycle : 3 times in each direction	1)As shown in item 2~6 2)Contact Resistance: 2Ω max. (final-after test)		

(F)NHDS-V SPECIFICATION

FILE No. : E-V-AD09
REV. : B
Page : 3 / 4

DURABILITY	
11	Operation Life

WEATHER-PROOF	
12	Resistance Low Temperature
13	Resistance High Temperature
14	Resistance Humidity

Measurements shall be made following the test set forth below: 1)25mA,24 V DC resistive load 2)Rate of Operation : 15~20 cycles/minute 3)Cycle of Operation : (F)NHDS-V TYPE : 1000 cycles	1)As shown in item 3,4 2)Contact Resistance: 2Ω max. (final-after test)
Following the test set forth below the sample shall be left in normal temperature and humidity conditions for an hour before measurements are made : 1)Temperature : -40±3℃ 2)Time : 96 hours	1)As shown in item 2~6 2)Contact Resistance: 2Ω max. (final-after test)
Following the test set forth below the sample shall be left in normal temperature and humidity conditions for an hour before measurements are made : 1)Temperature :85±2℃ 2)Time : 96 hours	1)As shown in item 3~6 2)Contact Resistance : 2Ωmax. (final-after test)
Following the test set forth below the sample shall be left in normal temperature and humidity conditions for an hour before measurements are made : 1)Temperature : 40±2℃ 2)Relative Humidity : 90~95% 3)Time : 96 hours	1)As shown in item 4~6 2)Contact Resistance : 2Ωmax. 3)Insulation Resistance: 10 MΩ min .

5. SOLDERING CONDITIONS:

- Condition for Soldering- (F)NHDS-V Series

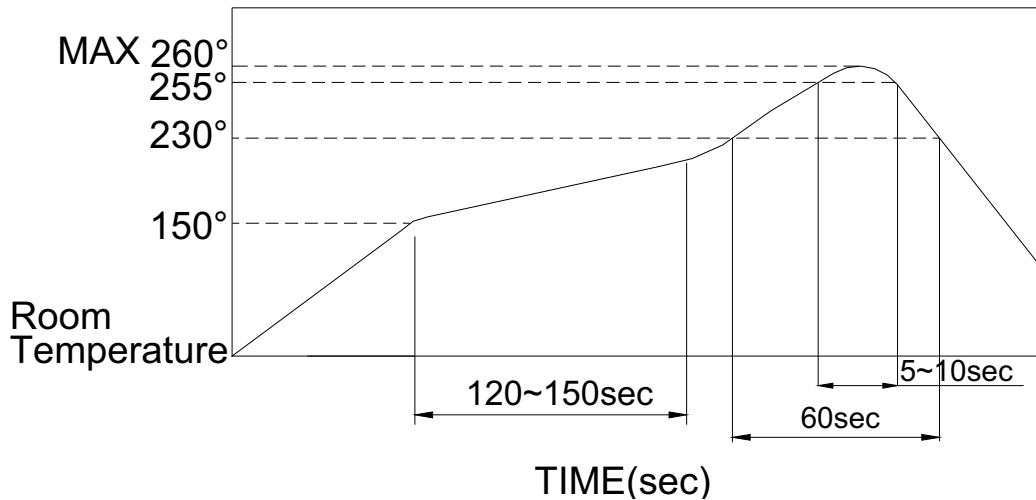

- The condition mentioned above is the temperature on the Cu foil of the PCB surface. There are cases where board's temperature greatly differs from switch's surface temperature depending on board's material, size, thickness, etc. Care, therefore, should be used not to allow switch's surface temperature to exceed 260°C.
- Manual Soldering

Soldering Temperature	Max,350°C
Continuous Soldering Time	Max,5 seconds

Precautions in Handling

- Care should be exercised so that flux from the upper part of the printed circuit board does not adhere to the switch.
- Don't clean the switch body except with top tape sealed type, which can only spray of cleaning method from top of s/w.
- Slide the (F)NHDS actuator from Z axial direction with in 30°~120° of max 300 gf / 10 sec operation.

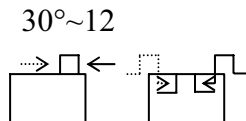

- The suggest tool for actuator adjust is as below. (example for 4 position)

