

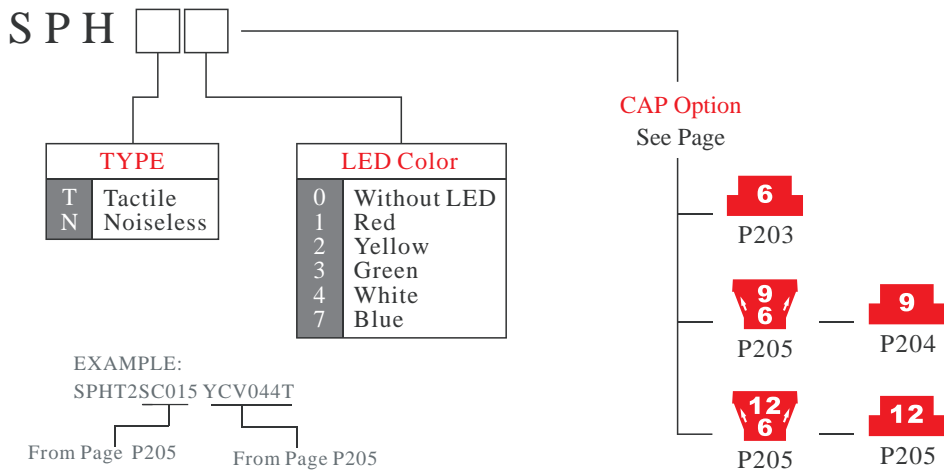

General Specifications	
Current Rating	: 50mA
Voltage Rating	: 12VDC
Dielectric Withstanding Voltage	: 250VAC for 1 minute
Contact Resistance	: 100m Ohm Max.(initial)
Insulation Resistance	: 100M Ohm Min.
Operating Force	: 230gf ± 50gf(Tactile)/ 60gf ± 10gf(Noiseless)
Total Travel(Tactile)	: 0.3mm ± 0.1mm
Total Travel(Noiseless)	: 1.0mm ± 0.3mm
Operating Life	: 1,000,000 cycles Min.
Solder Specifications	: 260 deg. for 3 seconds
Function	: Momentary(SPST)
Operating Temperature	: -10 deg.~+60 deg.

Materials	
Cap	: Polycarbonate (PC)
Base	: Polyamide (PA)
Reflector	: Polyoxymethylene (POM)
Switch Terminal	: Brass with gold plating
Action Dome	: Stainless steel with silver plating(Tactile) Phosphor Bronze with gold plating(Noiseless)
Sealing rubber	: Silicone

HOW TO ORDER



DIMENSION

PCB layout & Circuit Diagram

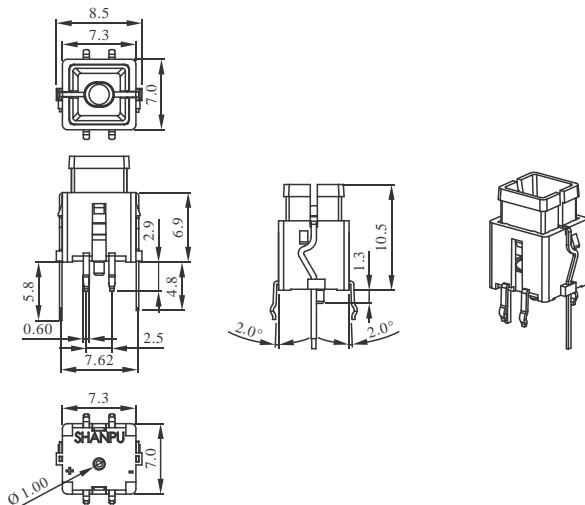
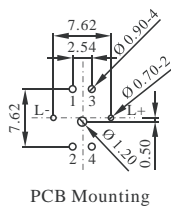
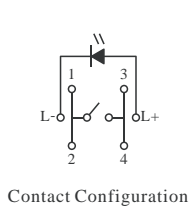

SPH Series

Noiseless Illuminated Tactile Switches

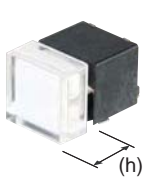

SPJ

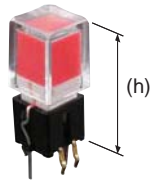

SPH

$$(h) = (h1) + (h2) + (h3)$$

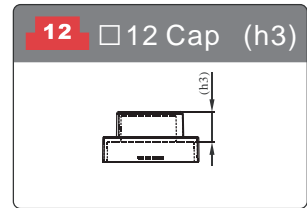
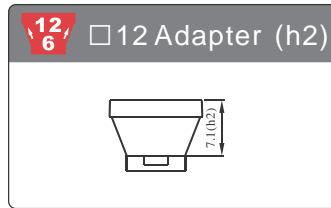
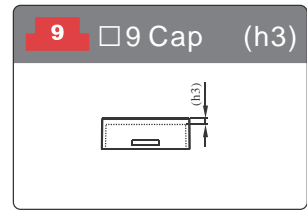
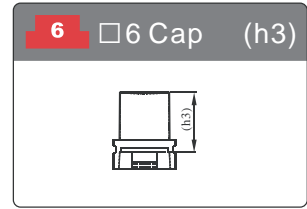
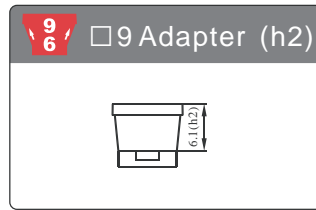
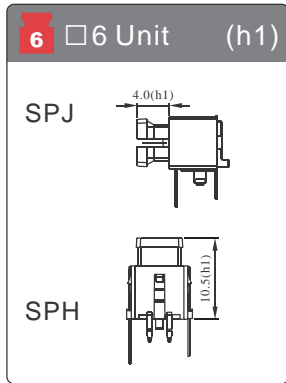

CAP OPTIONS

6 □6 Cap

Shape						
Dimension						
Transparent with Diffuser	YCA044TD	YCA043TD	—	—	—	—
Transparent	YCA044T	YCA043T	—	—	—	—
Ice	—	—	YCA045A	YCA046A	YCV003A	YCV007A
Snow	—	—	YCA045B	YCA046B	YCV003B	YCV007B
Transparent Black	—	—	YCA045C	YCA046C	—	—
Red	—	—	—	—	YCV0031	YCV0071
Yellow	—	—	—	—	YCV0032	YCV0072
Green	—	—	—	—	YCV0033	YCV0073
White	YCA0444	YCA0434	—	—	YCV0034	YCV0074
Orange	—	—	—	—	YCV0036	YCV0076
Blue	—	—	—	—	YCV0037	YCV0077
SPJ (h)	5.5mm	5.5mm	11.1mm	11.1mm	12.0mm	12.0mm
SPH (h)	12mm	12mm	17.6mm	17.6mm	18.5mm	18.5mm

*YCV003 Cover+YCA009 Red cap=YCV0031

*Only for SPH

*YCV003 Cover+YCA051 Red cap=YCV0071

Shape					
Dimension					
Transparent with Diffuser	YCA047TD	YCA010TD	YCA011TD	YCA012TD	YCA013TD
Transparent	—	—	—	—	—
Ice	—	—	—	—	—
Snow	—	—	—	—	—
Transparent Black	—	—	—	—	—
Red	—	—	—	—	—
Yellow	—	—	—	—	—
Green	—	—	—	—	—
White	YCA0474	YCA0104	YCA0114	YCA0124	YCA0134
Black	—	—	—	—	—
Orange	—	—	—	—	—
Blue	—	—	—	—	—
Grey	—	—	—	—	—

Shape				
Dimension				
Transparent with Diffuser	—	—	—	—
Transparent	—	—	—	—
Ice	—	—	—	—
Snow	YCA016B	YCA017B	YCA018B	YCA019B
Transparent Black	—	—	—	—
Red	YCA0161	YCA0171	YCA0181	YCA0191
Yellow	YCA0162	YCA0172	YCA0182	YCA0192
Green	YCA0163	YCA0173	YCA0183	YCA0193
White	YCA0164	YCA0174	YCA0184	YCA0194
Black	YCA0165	YCA0175	YCA0185	YCA0195
Orange	YCA0166	YCA0176	YCA0186	YCA0196
Blue	YCA0167	YCA0177	YCA0187	YCA0197
Grey	YCA0169	YCA0179	YCA0189	YCA0199

12 □12 Cap

Shape						
Dimension						
Transparent	YCV037T	YCV038T	YCV039T	YCV040T	YCV041T	YCV042T
Shape						
Dimension						
Transparent	YCV043T	YCV044T				
White	YCV0434	YCV0444				

Adaptet option	9 6 □9 Adapter	12 6 □12 Adapter
Dimension		
Without Cap	—	SC06
Transparent	SC01T	—
Ice	SC01A	—
Snow	SC01B	—
Transparent Black	—	—
Red	SC011	—
Yellow	SC012	—
Green	SC013	—
White	SC014	—
Orange	SC016	—
Blue	SC017	—
SPJ (h)	11.1mm	10.1mm
SPH (h)	17.6mm	16.6mm

*SC01 Fit □12 Cover

*SC06 Fit □9 Cap

12

9