

SMD gewinkelt 90° (FP)

Gedrehte Kontakte / Bauhöhe 6.3 mm

90° SMD connectors (FP)

Machined contacts / Mounting height 6.3 mm

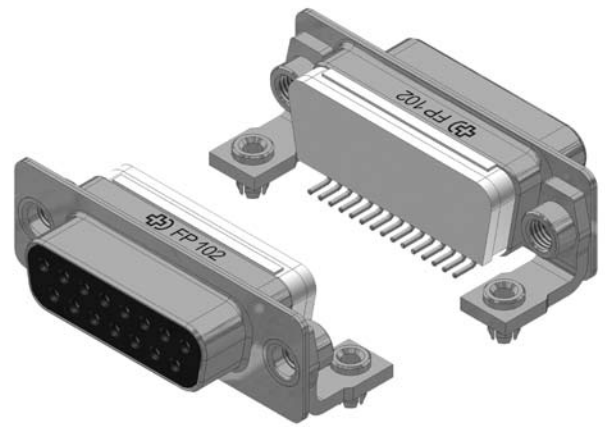

Stiftleiste

Plug connector

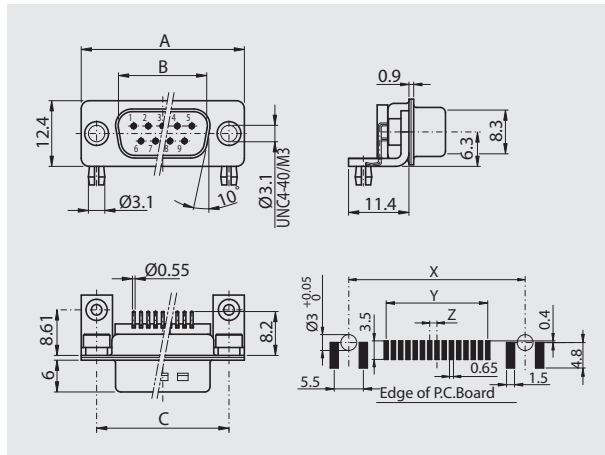

Buchsenleiste

Socket connector

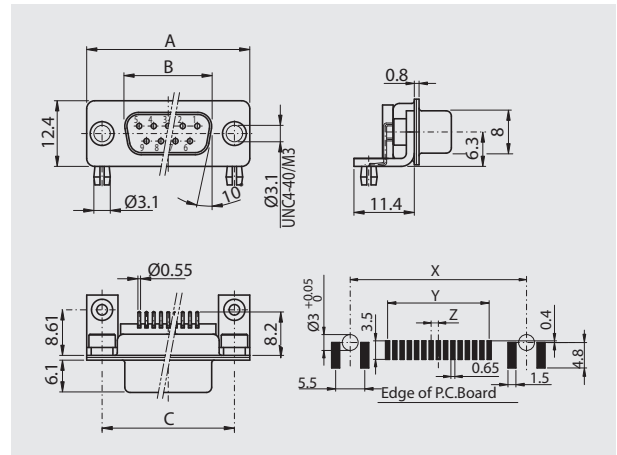

Polzahl

No. of pos.	A	B	C/X	Y	Z
09	30.80	16.90	25.00	10.98	01.37
15	39.20	25.20	33.30	19.20	01.37
25	53.10	39.00	47.00	33.12	01.38
37	69.50	55.40	63.50	49.68	01.38

Polzahl

No. of pos.	A	B	C/X	Y	Z
09	30.80	16.30	25.00	10.98	01.37
15	39.20	24.60	33.30	19.20	01.37
25	53.10	38.40	47.00	33.12	01.38
37	69.50	54.80	63.50	49.68	01.38

Bestellbezeichnung

Polzahl	Gehäuse verzinkt
No. of pos.	Tinned shell
09	D 09 PYCSMD x FP yyy z
15	D 15 PYCSMD x FP yyy z
25	D 25 PYCSMD x FP yyy z
37	D 37 PYCSMD x FP yyy z

Order information

Polzahl	Gehäuse verzinkt
No. of pos.	Tinned shell
09	D 09 SYCSMD x FP yyy z
15	D 15 SYCSMD x FP yyy z
25	D 25 SYCSMD x FP yyy z
37	D 37 SYCSMD x FP yyy z

Tragen Sie anstelle der yyy den gewünschten Filtercode ein.

To request the filter code, replace the yyy.

Filtercode	Filterwert	Filtercode	Filterwert	Filtercode	Filterwert	Filtercode	Filterwert
Filtercode	Filter values	Filtercode	Filter values	Filtercode	Filter values	Filtercode	Filter values
331	330 pF	681	680 pF	152	1500 pF	562	5600 pF
471	470 pF	102	1000 pF	222	2200 pF	682	6800 pF

Anstelle des x die gewünschte Güteklasse 1 oder 2 einfügen. Andere Vergoldungen auf Anfrage.
Tragen Sie anstelle des z den gewünschten Gewindetypen UN (UNC4-40) oder M3 ein.

To request class 1 oder 2 quality, replace the x.
Other gold platings on request.
To request the thread type, replace the z with UN (UNC4-40) or M3.