

Wire Wrap
Gedrehte Kontakte

Wire Wrap
Machined contacts

Stiftleiste

Plug connector

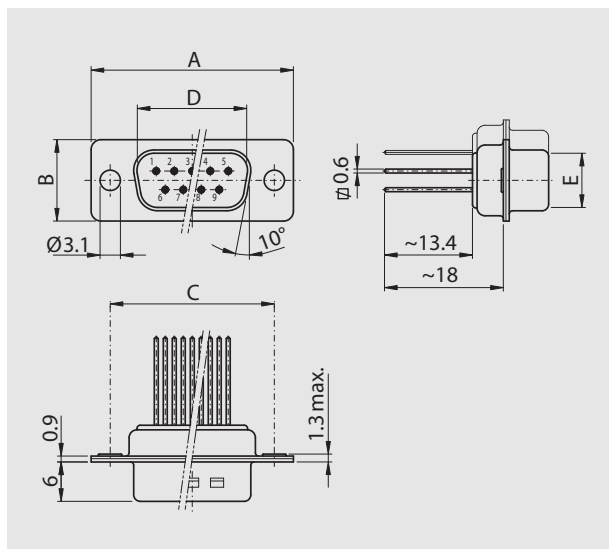

Buchsenleiste

Socket connector

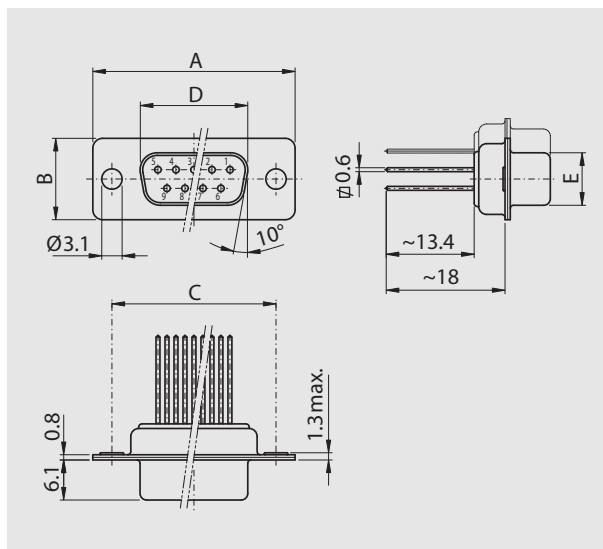

Polzahl

No. of pos.	A	B	C	D	E
09	30.80	12.40	25.00	16.79	08.23
15	39.20	12.40	33.30	25.12	08.23
25	53.10	12.40	47.04	38.84	08.23
37	69.50	12.40	63.50	55.30	08.23
50	67.00	15.40	61.10	52.68	10.95

Polzahl

No. of pos.	A	B	C	D	E
09	30.80	12.40	25.00	16.46	08.02
15	39.20	12.40	33.30	24.79	08.02
25	53.10	12.40	47.04	38.50	08.02
37	69.50	12.40	63.50	54.96	08.02
50	67.00	15.40	61.10	52.55	10.87

Bestellbezeichnung

Polzahl	Gehäuse chromatiert	Gehäuse verzinkt
No. of pos.	Chromated shell	Tinned shell
09	DT 09 PW3 x	DTS 09 PW3 x
15	DT 15 PW3 x	DTS 15 PW3 x
25	DT 25 PW3 x	DTS 25 PW3 x
37	DT 37 PW3 x	DTS 37 PW3 x
50	DT 50 PW3 x	DTS 50 PW3 x

Anstelle des x am Ende der Artikelbezeichnung die gewünschte Güteklasse 1 oder 2 einfügen.
Andere Vergoldungen auf Anfrage.

Order information

Polzahl	Gehäuse chromatiert	Gehäuse verzinkt
No. of pos.	Chromated shell	Tinned shell
09	DT 09 SW3 x	DTS 09 SW3 x
15	DT 15 SW3 x	DTS 15 SW3 x
25	DT 25 SW3 x	DTS 25 SW3 x
37	DT 37 SW3 x	DTS 37 SW3 x
50	DT 50 SW3 x	DTS 50 SW3 x

To request class 1 or 2 quality, replace the x at the end of the part no.
Other gold platings on request.