

SMD gewinkelt 90° – Gegurtet

Gedrehte Kontakte / Bauhöhe 3.6 mm /
 Rollen Aussendurchmesser 330 mm / 150 Stück pro Rolle

90° SMD connectors – Tape and reel

Machined contacts / Mounting height 3.6 mm /
 Reel outside diameter 330 mm / 150 pieces per reel

Stiftleiste

Plug connector

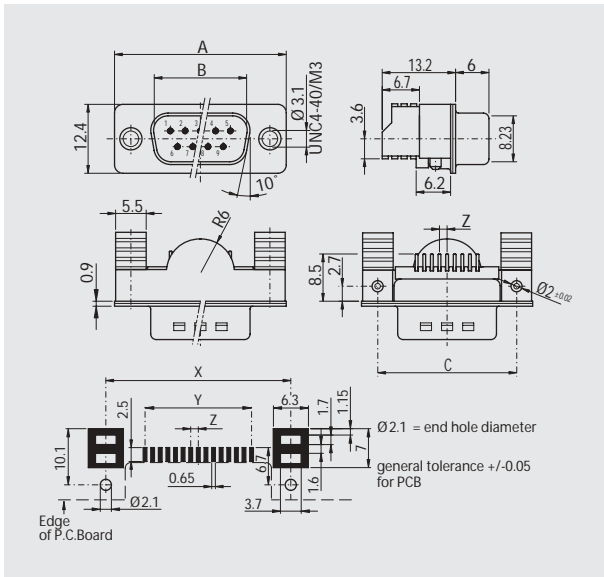

Buchsenleiste

Socket connector

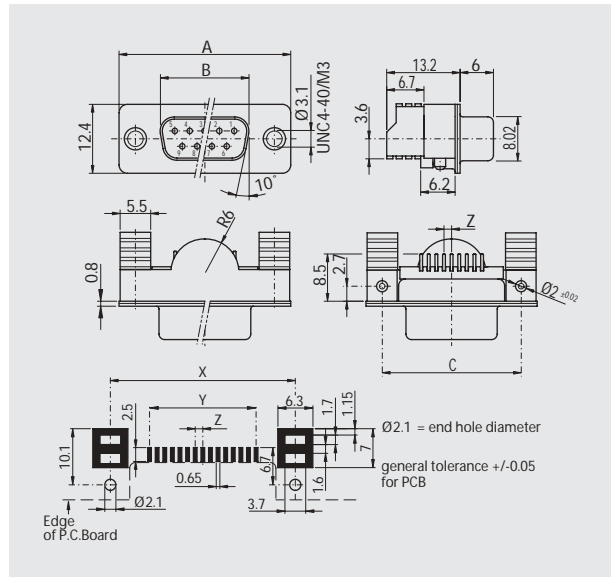

Polzahl

No. of pos.	A	B	C/X	Y	Z
09	30.80	16.79	25.00	10.98	01.37
15	39.20	25.12	33.30	19.20	01.37
25	53.10	38.84	47.00	33.12	01.38
37	69.50	55.30	63.50	49.68	01.38

Polzahl

No. of pos.	A	B	C/X	Y	Z
09	30.80	16.46	25.00	10.98	01.37
15	39.20	24.79	33.30	19.20	01.37
25	53.10	38.50	47.00	33.12	01.38
37	69.50	54.96	63.50	49.68	01.38

Bestellbezeichnung

Polzahl	Gehäuse chromatiert	Gehäuse verzinkt
No. of pos.	Chromated shell	Tinned shell
09	DT 09 PYCESMD x z-TR	DTS 09 PYCESMD x z-TR
15	DT 15 PYCESMD x z-TR	DTS 15 PYCESMD x z-TR
25	DT 25 PYCESMD x z-TR	DTS 25 PYCESMD x z-TR
37	DT 37 PYCESMD x z-TR	DTS 37 PYCESMD x z-TR

Anstelle des x am Ende der Artikelbezeichnung die gewünschte Güteklasse 1 oder 2 einfügen.
 Andere Vergoldungen auf Anfrage.

Tragen Sie anstelle des z den gewünschten Gewindetypen UN (UNC4-40) oder M3 ein.

Order information

Polzahl	Gehäuse chromatiert	Gehäuse verzinkt
No. of pos.	Chromated shell	Tinned shell
09	DT 09 SYCESMD x z-TR	DTS 09 SYCESMD x z-TR
15	DT 15 SYCESMD x z-TR	DTS 15 SYCESMD x z-TR
25	DT 25 SYCESMD x z-TR	DTS 25 SYCESMD x z-TR
37	DT 37 SYCESMD x z-TR	DTS 37 SYCESMD x z-TR

To request class 1 or 2 quality, replace the x at the end of the part no.
 Other gold platings on request.

To request the thread type, replace the z with UN (UNC4-40) or M3.