

Lötstift gewinkelt 90°, 8.4 mm

Gedrehte Kontakte / Eurostyle

90° Solder pin, 8.4 mm

Machined contacts / Eurostyle

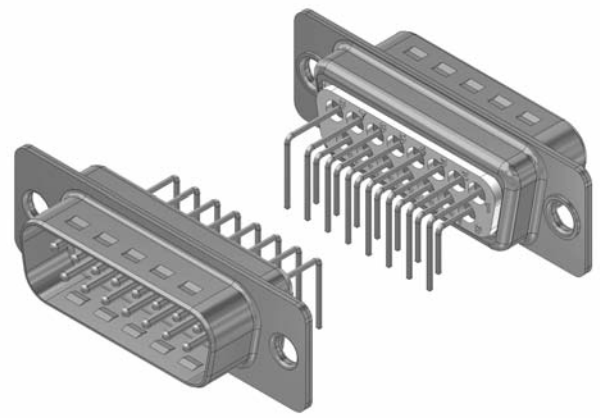

Stiftleiste
Plug connector

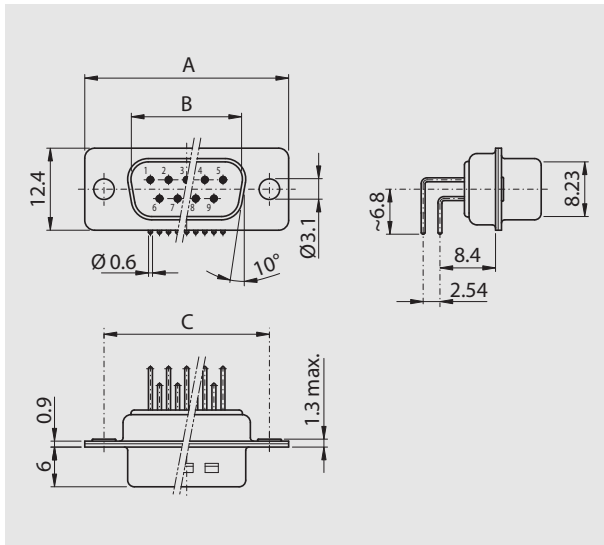

Buchsenleiste
Socket connector

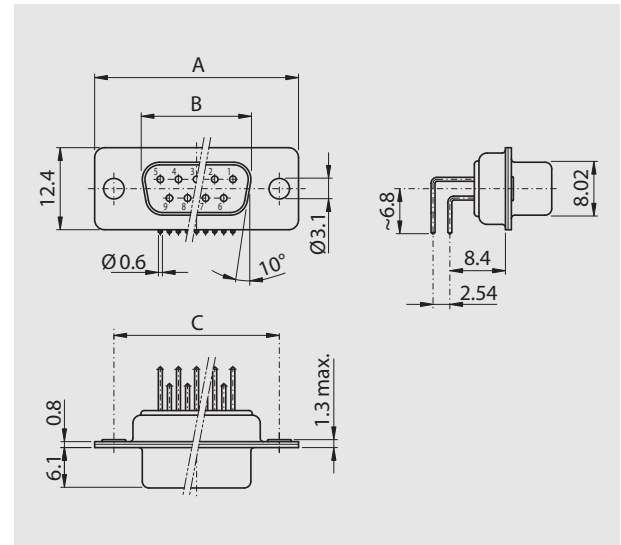

Polzahl			
No. of pos.	A	B	C
09	30.80	16.79	25.00
15	39.20	25.12	33.30
25	53.10	38.84	47.04
37	69.50	55.30	63.50

Polzahl			
No. of pos.	A	B	C
09	30.80	16.46	25.00
15	39.20	24.79	33.30
25	53.10	38.50	47.04
37	69.50	54.96	63.50

Bestellbezeichnung

Polzahl	Gehäuse chromatiert	Gehäuse verzinkt
No. of pos.	Chromated shell	Tinned shell
09	DT 09 PYC-E x	DTS 09 PYC-E x
15	DT 15 PYC-E x	DTS 15 PYC-E x
25	DT 25 PYC-E x	DTS 25 PYC-E x
37	DT 37 PYC-E x	DTS 37 PYC-E x

Anstelle des x am Ende der Artikelbezeichnung die gewünschte Güteklasse 1 oder 2 einfügen.
Andere Vergoldungen auf Anfrage.

Order information

Polzahl	Gehäuse chromatiert	Gehäuse verzinkt
No. of pos.	Chromated shell	Tinned shell
09	DT 09 SYC-E x	DTS 09 SYC-E x
15	DT 15 SYC-E x	DTS 15 SYC-E x
25	DT 25 SYC-E x	DTS 25 SYC-E x
37	DT 37 SYC-E x	DTS 37 SYC-E x

To request class 1 or 2 quality, replace the x at the end of the part no.
Other gold platings on request.