

TECHNICAL CHARACTERISTICS

1. General Characteristics

Dimension: 14.90L x 16.30W x 1.90H mm
 Weight: Approx. 0.40 g
 Contact principle: Friction technology
 Operating position: Shaft up / Down / Horizontal
 Mounting System: SMT Type (without post)
 Durability: 5,000 cycles min.

2. Mechanical Characteristics

Insulation material: Thermoplastic, UL 94V-0
 RoHS Directive 2002/95/EC Compliant

3. Electrical Characteristics

Number of contacts: 6 pins
 Contact resistance: 50 mΩ typical, 100 mΩ max.
 Insulation resistance: >1000 MΩ / 500 VDC

4. Solderability

Wave: Not applicable
 IR reflow: 260°C, 10 sec. Max.
 Manual soldering: 360°C, 3 sec. Max.

5. Environmental Characteristics

Operating temperature: - 40°C ~ + 85°C
 Operating humidity: 10 % ~ 95 % RH
 Storage temperature: - 40°C ~ + 85°C
 Storage humidity: 10 % ~ 95 % RH

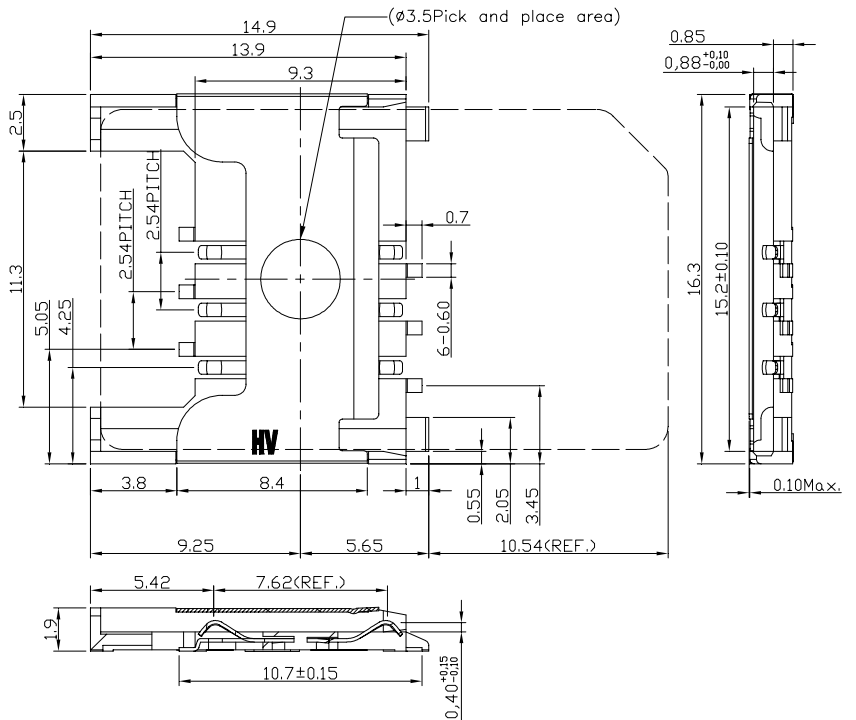

Unit: mm; Tolerances: ±0.15 mm
Mechanical outline dimension

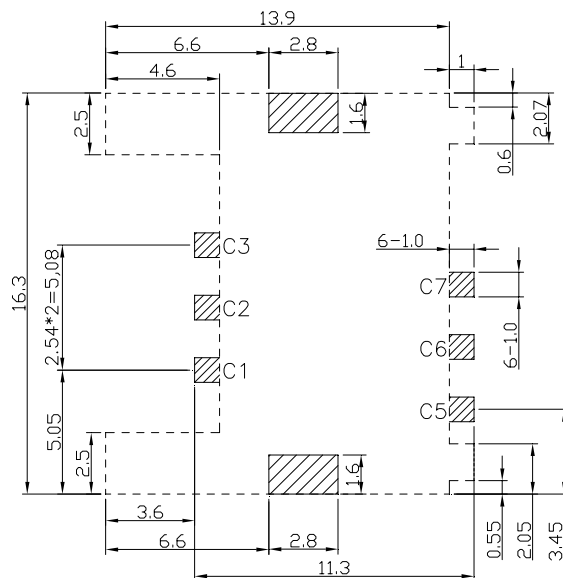

Unit: mm; Tolerances: ±0.05 mm
Reference dimension for PCB layout

H&V SIM Card Connector

Model No.: ICC-425

Revision: 1.5

Date: FEB. 13, 2006