

TECHNICAL CHARACTERISTICS

1. General Characteristics

Dimension: 18.40L x 16.50W x 1.45H mm

Weight: Approx. 0.42 g

Contact principle: Friction technology

Operating position: Shaft up / Down / Horizontal

Mounting System: SMT Type (without post)

Durability: 5,000 cycles min.

2. Mechanical Characteristics

Insulation material: Thermoplastic, UL 94V-0

RoHS Directive 2002/95/EC Compliant

3. Electrical Characteristics

Number of contacts: 6, 8 pins (optional)

Contact resistance: 50 mΩ typical, 100 mΩ max.

Insulation resistance: >1000 MΩ / 500 VDC

4. Solderability

Wave: Not applicable

IR reflow: 260°C, 10 sec. Max.

Manual soldering: 360°C, 3 sec. Max.

5. Environmental Characteristics

Operating temperature: - 40°C ~ + 85°C

Operating humidity: 10 % ~ 95 % RH

Storage temperature: - 40°C ~ + 85°C

Storage humidity: 10 % ~ 95 % RH

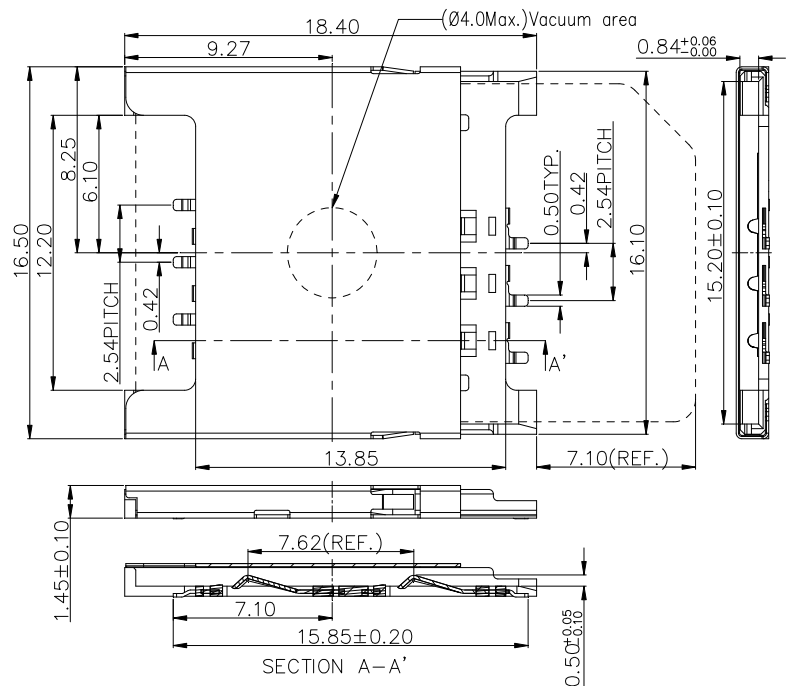

Unit: mm; Tolerances: ±0.15 mm

Mechanical outline dimension

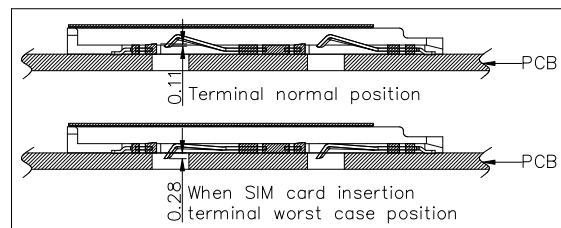
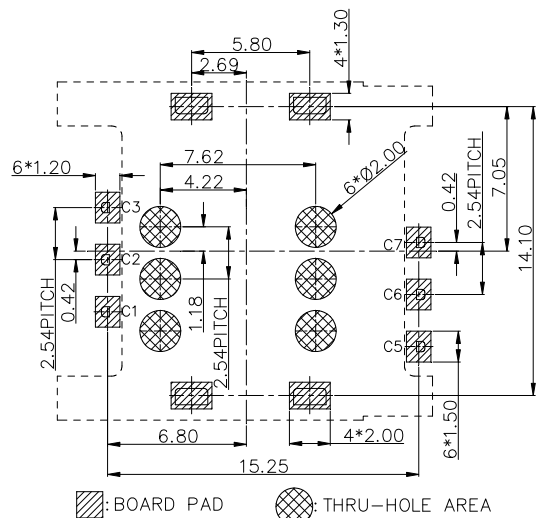

Unit: mm; Tolerances: ±0.05 mm

Reference dimension for PCB layout

H&V SIM Card Connector

Model No.: ICC-435 6Pin

Revision: 1.0

Date: JAN. 01, 2011