

RoHS COMPLIANT

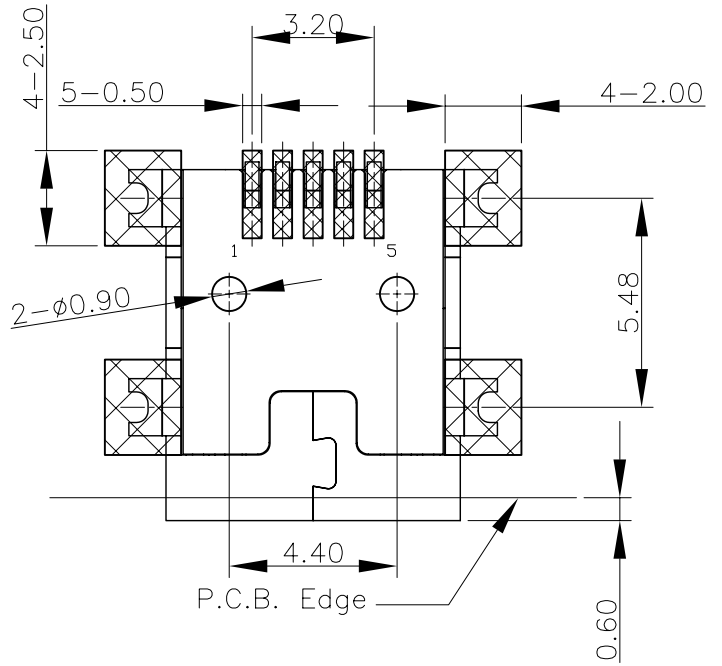

RECOMMEND P.C.B. LAYOUT

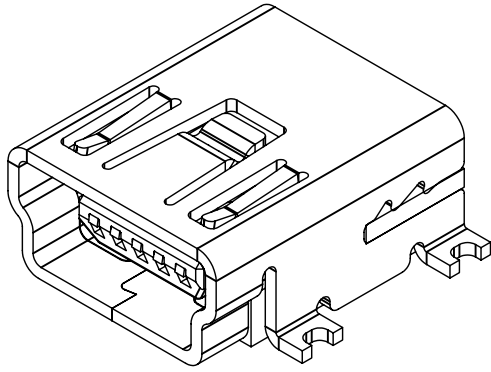
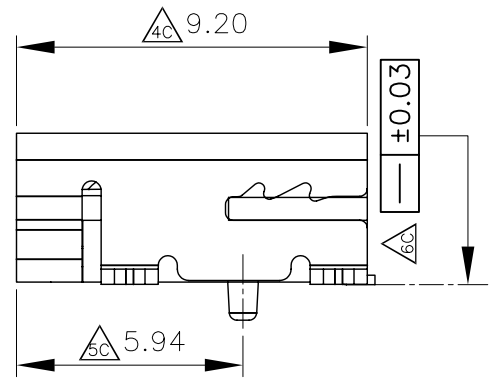
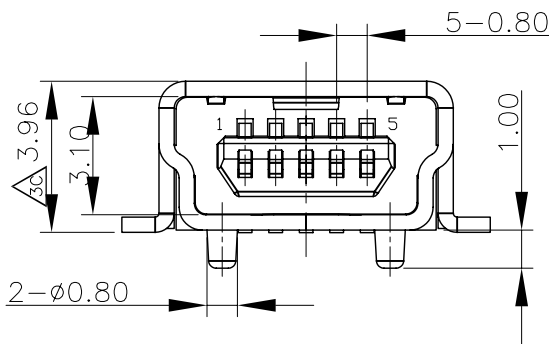
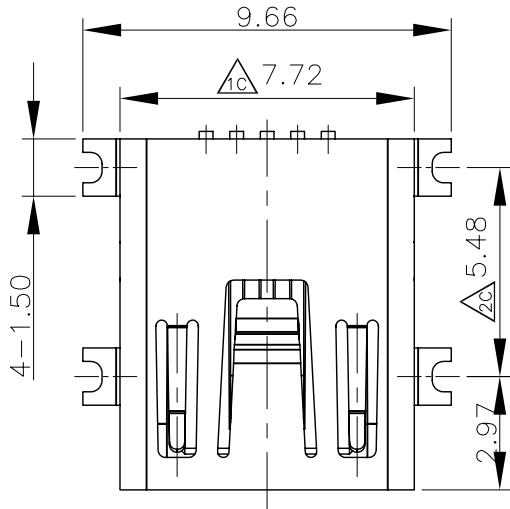

Material:
 Housing: Thermoplastic UL 94V-0.
 Contacts: Phosphor Bronze.
 Plating: Gold Plating Over Nickel In Contact.
 Tin Plating Over Nickel In Solder Area.
 Shell: SPCC

※凡標註△記號者，為品管檢驗之尺寸。

設計DR. Wing 2007-12-24	核准APPD. Jerry 2007-12-24	容許公差 .XXX ±0.10 .XX ±0.25 .X ±0.38 X ±0.50 ANG ±3°	TOLERANCE	品名 ARTICLE Mini USB B Type Connector
版本說明 REVISION NOTE -----依E302-0709037新產品開發申請-----				圖號 DWG NO. 6130A10030
				單位 UNIT mm 比例 SCALE 1/5 張數 SHEET 1/1 版本 REV. A

KINSUN

慶陞公司標準

主題 Subject	6130 Mini USB B TYPE CONNECTOR	文件編號 NO.	EN-6130-P0101	版本 REV.	C
		核准 APPD.	Jerry	製作者 DR.	Wing <small>2008.06.11</small>

(1.)

包裝下帶:P6130R0100

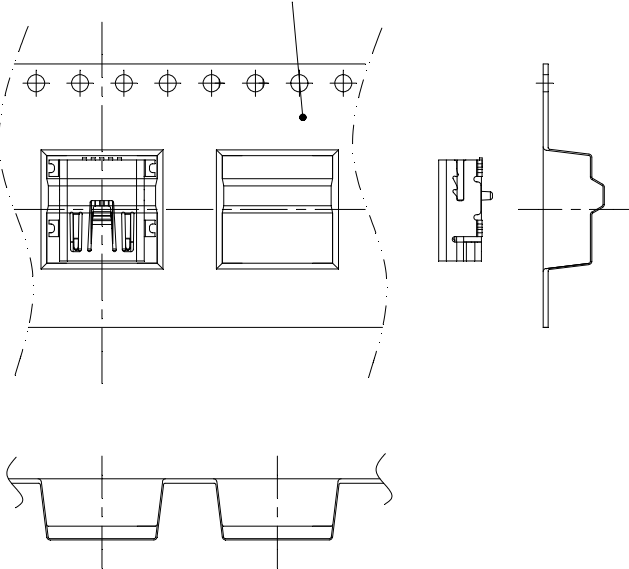

1. 將裝配後成品依上圖所示方向依序放入包裝下帶內。

(2.)

自黏式包裝上帶
P6130R0200

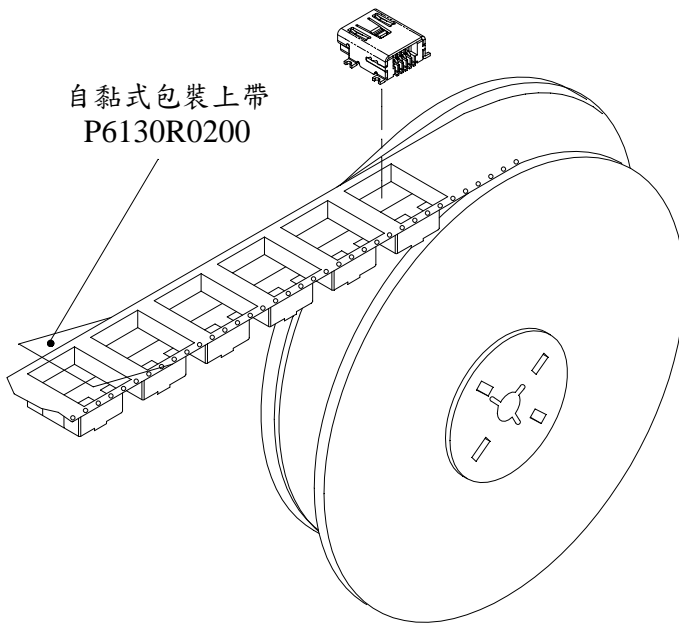

2. 成品依序放入包裝下帶後，依圖面標示方向進行捲繞，每盤包裝數量為50pcs。(包裝下帶空格保留，內空0格外空5格)。

(3.)

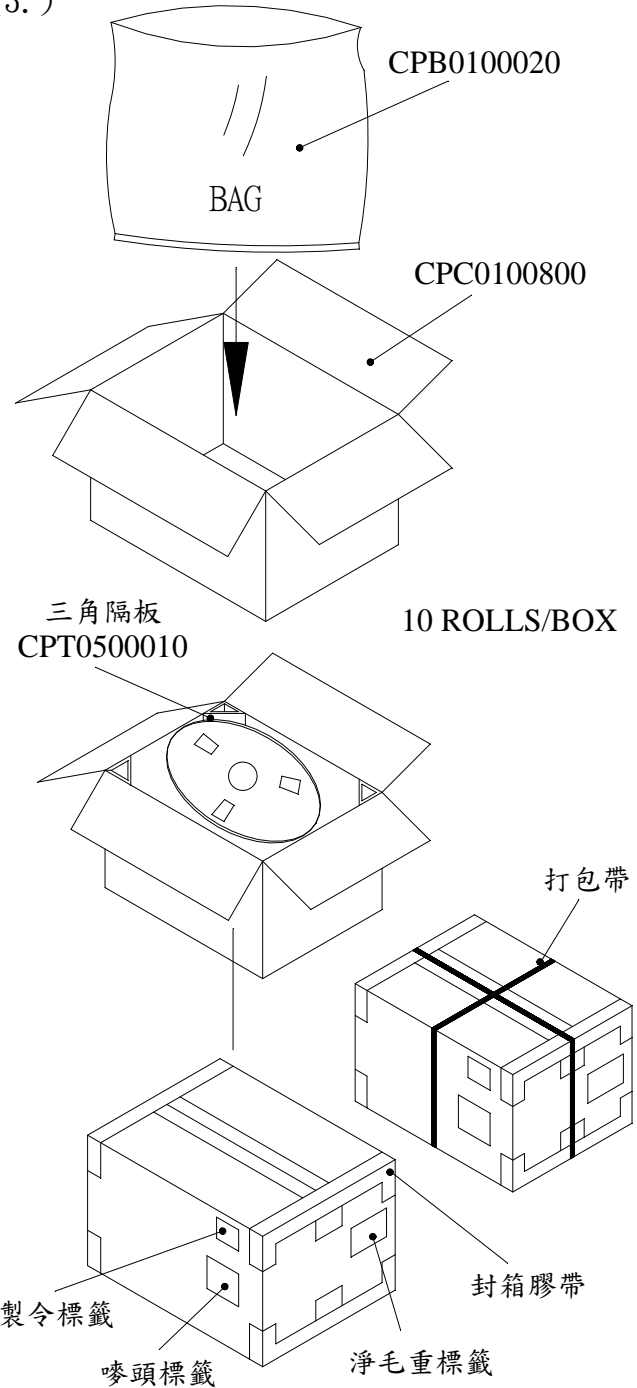

3. 將防水袋(CPB0100020)套入外箱(CPC0100800)內鋪齊，在將完成包裝之捲盤放入外箱中依圖示貼上標籤，以封箱膠帶封箱，依圖示打(封)箱四周內，放四個三角隔板

4. 若為不滿箱，請用牛皮紙填充。