

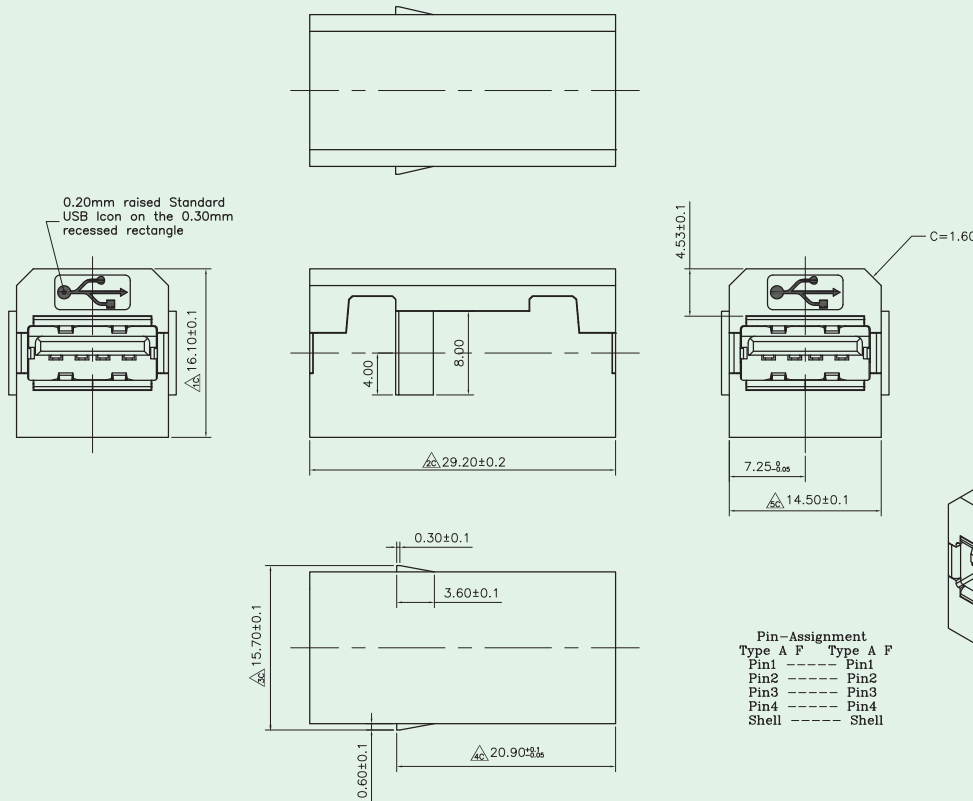

# USB A-A TYPE ADAPTOR

# KINSUN



## APPLICATION AND FEATURES

1. Compact and low profile design for saving space
2. High reliable contact with low insertion force.
3. Straight and right angle type facilitate engineering design.
4. Mate with flexible Printed Circuit.

## SPECIFICATIONS

Meets USB2.0 specifications

Current Rating : 1.5 A Max.

Insulator resistance : 1000 Megohms min .

Contact resistance : 30 m ohm Max.

DWV:500v AC/60s Pin to Pin;1000v AC/60s Pin to shell.

Operating Temperature : -40 °C +85 °C

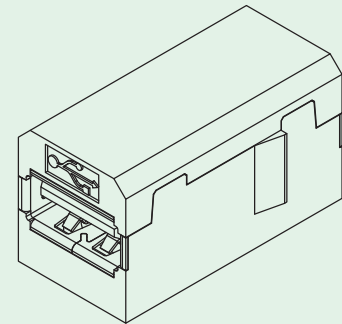

## Materials

- **Housing** : Engineering thermo plastic  
Flammability Rating UL 94V-0.
- **Contacts** : Phosphor Bronze t=0.25mm.
- **Shell** : Brass t=0.30mm Plating Ni 40µ".



## Ordering Information

# 6180 Series