

NOTES (UNLESS OTHERWISE NOTED):

1. MATERIAL: TIN BRASS ALLOY
2. FINISH: POST-PLATED, 0.4-1.5µm MATTE TIN OVER 1.2µm (MIN) SULFAMATE NICKEL
3. SEE SHEET 2 OF 2 FOR PART NUMBER OPTIONS AND PACKAGING DETAILS.

REVISIONS				
ZONE	REV.	DESCRIPTION	DATE	APPROVED
E		UPDATED PART AND ADDED REELING OPTIONS	24JAN2012	JDP
F		MOVED PACKAGING DETAILS TO SHEET 2	1APR2014	JDP

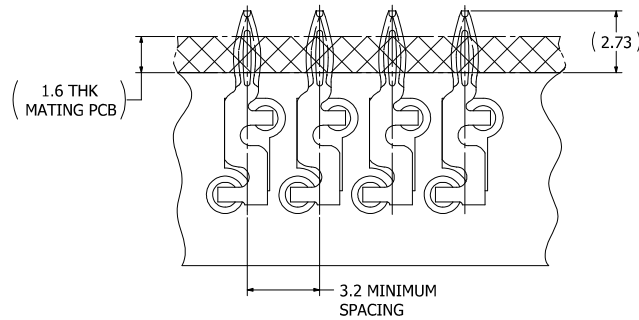
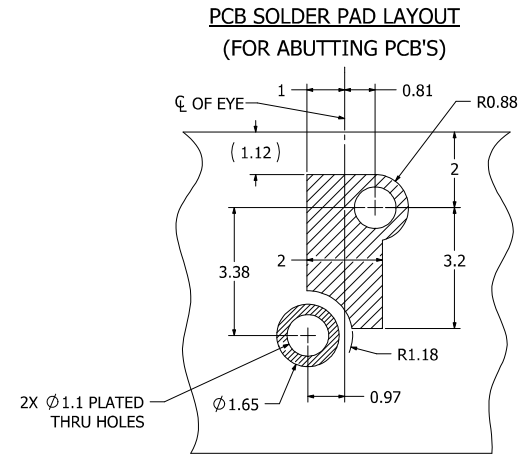
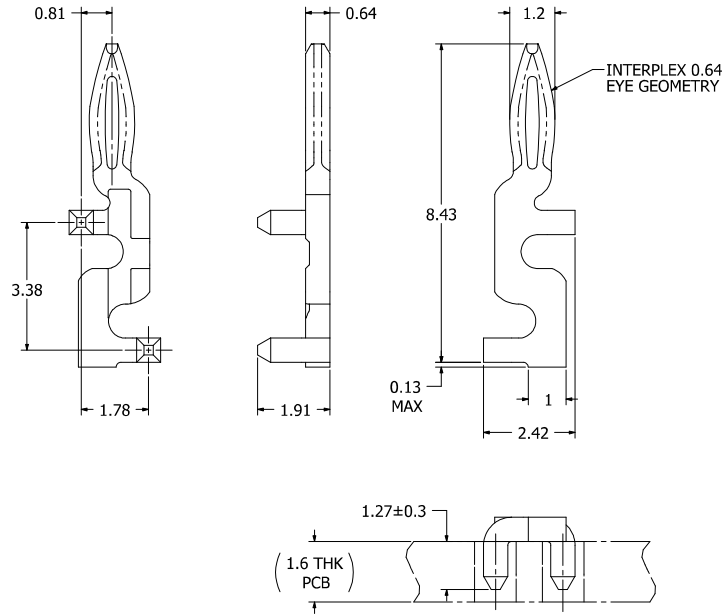
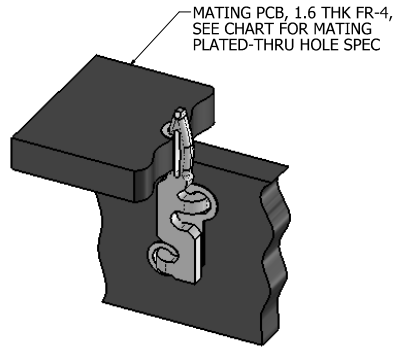

REQUIRED PCB HOLE CONSTRUCTION	
DRILL	Ø 1.151 ± 0.025 mm
COPPER THICKNESS	0.025 mm MIN
FINAL IMMERSION PLATED HOLE DIAMETER	Ø 1.020 ± 0.076 mm

PART NUMBER	PACKAGING
IPX15277-01	ON REEL W/ CARRIER
IPX15277-02	SINGULATED IN BULK PACK
IPX15277-03	TAPE & REEL

UNLESS OTHERWISE SPECIFIED:	DRAWN	NAME	DATE
DIMENSIONS ARE IN mm	CHECKED	SCHNEIDER	24MAY2010
TOLERANCES:			
X ±			
.XX ±			
.XXX ±			
ANGULAR: ± °			
MATERIAL	SEE NOTES		
FINISH	SEE NOTES		
DO NOT SCALE DRAWING			

CUSTOMER PRINT		
<i>Interplex Industries</i>		
TITLE: 0.64 SMT PRESS FIT		
SIZE	DWG. NO.	REV
C	E-IPX15277	F
SHEET 1 OF 2		

PROPRIETARY & CONFIDENTIAL

THE INFORMATION CONTAINED IN THIS DRAWING IS THE SOLE PROPERTY OF INTERPLEX INDUSTRIES. ANY DISSEMINATION IN PART OR AS A WHOLE WITHOUT THE WRITTEN PERMISSION OF INTERPLEX INDUSTRIES IS PROHIBITED.

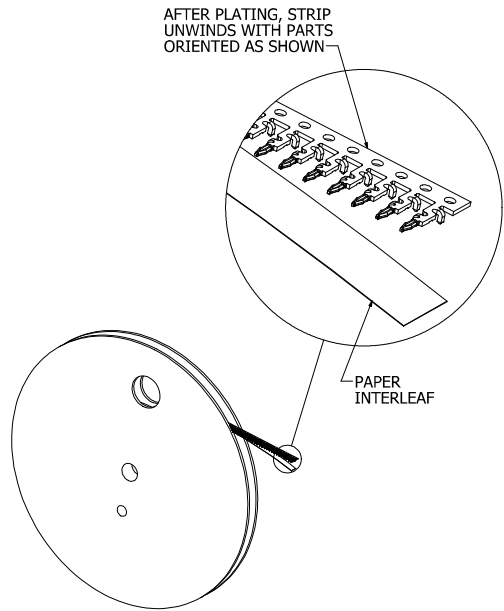

IPX15277-01
ON REEL W/ CARRIER
15" DIA CORRUGATED PLASTIC REEL
5,000 PARTS PER REEL

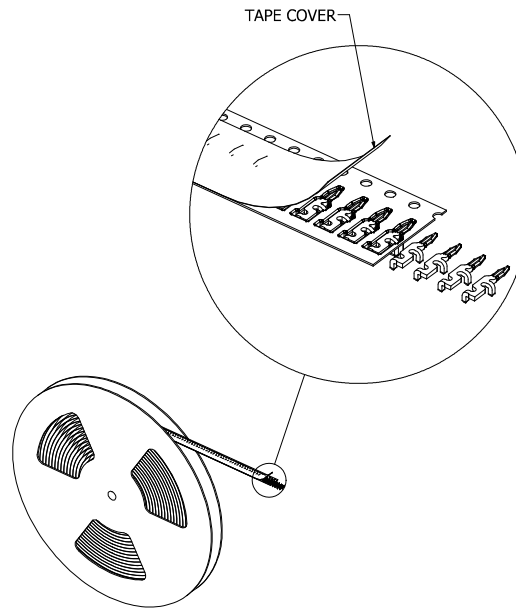

IPX15277-03
ON TAPE & REEL
13" DIA PLASTIC REEL
5,000 PARTS PER REEL

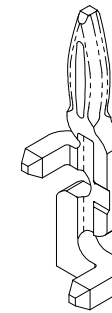

IPX15277-02
SINGULATED

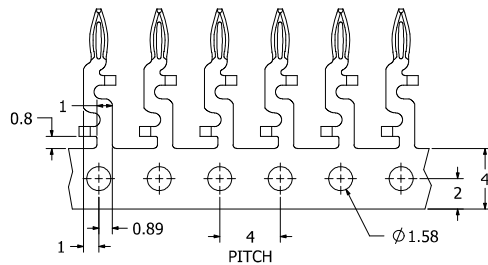

DETAILS OF IPX15277-01
ON REEL W/ CARRIER

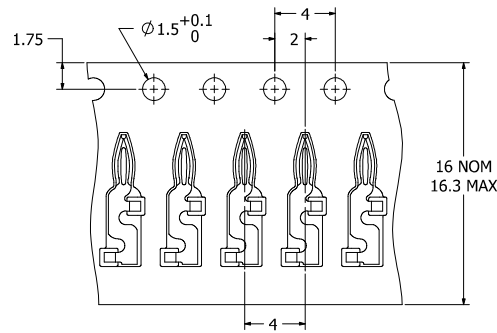

DETAILS OF IPX15277-03
ON TAPE & REEL

PART NUMBER	PACKAGING
IPX15277-01	ON REEL W/ CARRIER
IPX15277-02	SINGULATED IN BULK PACK
IPX15277-03	TAPE & REEL

CUSTOMER PRINT

Interplex Industries

TITLE:
0.64 SMT PRESS FIT

SIZE DWG. NO. REV
C E-IPX15277 **F**

SHEET 2 OF 2

UNLESS OTHERWISE SPECIFIED:	NAME	DATE
DIMENSIONS ARE IN mm	DRAWN: SCHNEIDER	24MAY2010
TOLERANCES:	CHECKED:	
X ±		
XX ±		
XXX ±		
ANGULAR: ± °		
MATERIAL	SEE NOTES	WHERE USED:
FINISH	SEE NOTES	
DO NOT SCALE DRAWING		

PROPRIETARY & CONFIDENTIAL

THE INFORMATION CONTAINED IN THIS DRAWING IS THE SOLE PROPERTY OF INTERPLEX INDUSTRIES. ANY DISSEMINATION IN PART OR AS A WHOLE WITHOUT THE WRITTEN PERMISSION OF INTERPLEX INDUSTRIES IS PROHIBITED.