

Wire-Wrap Präz.-Buchsenleisten RM 2,54mm, 1-/2-reihig Wire-Wrap Precision Female Headers, 2.54mm Pitch, Single/Double Row

Technische Daten / Technical Data

Isolierkörper <i>Insulator</i>	Thermoplastischer Kunststoff, nach UL94 V-0 <i>Thermoplastic, rated UL94 V-0</i>
Kontaktmaterial <i>Contact Material</i>	Hülse: Messing gedreht Feder: 6-Lamellen-Clip, Beryllium-Kupfer <i>Sleeve: screw machined brass Clip: 6-Finger-Clip, Beryllium-Copper</i>
Kontaktoberfläche <i>Contact Surface</i>	Lt. Oberflächenoptionen, über Ni (1,3 ... 2,5µm) <i>Acc. to options (see below), over Ni (1.3 ... 2.5µm)</i>
Durchgangswiderstand <i>Contact Resistance</i>	< 10mΩ
Isolationswiderstand <i>Insulation Resistance</i>	> 1000MΩ
Spannungsfestigkeit <i>Test Voltage</i>	1kV _{RMS}
Nennspannung <i>Voltage Rating</i>	100V _{RMS} / 150V _{DC}
Nennstrom <i>Current Rating</i>	3A
Temperaturbereich <i>Temperature Range</i>	-55°C ... +125°C
Verarbeitung <i>Processing</i>	Wellen- oder Reflow-Lötverfahren <i>Wave or reflow soldering</i>

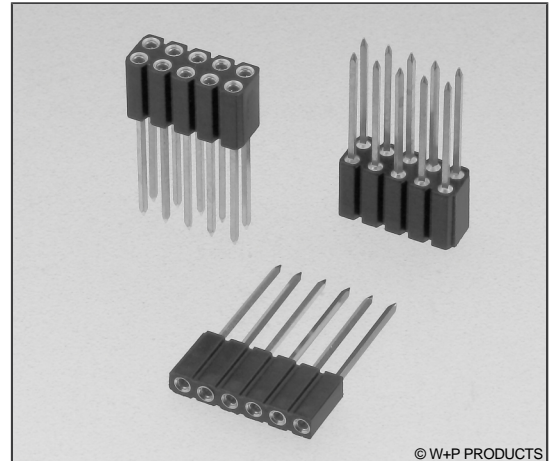

© W+P PRODUCTS

Einsetzbar für Rundstifte Ø0,65-0,85mm
oder Vierkantstifte 0,635mm.
Accept Ø0.65-0.85mm round pins or 0.635mm square pins.

PCB - LAYOUT

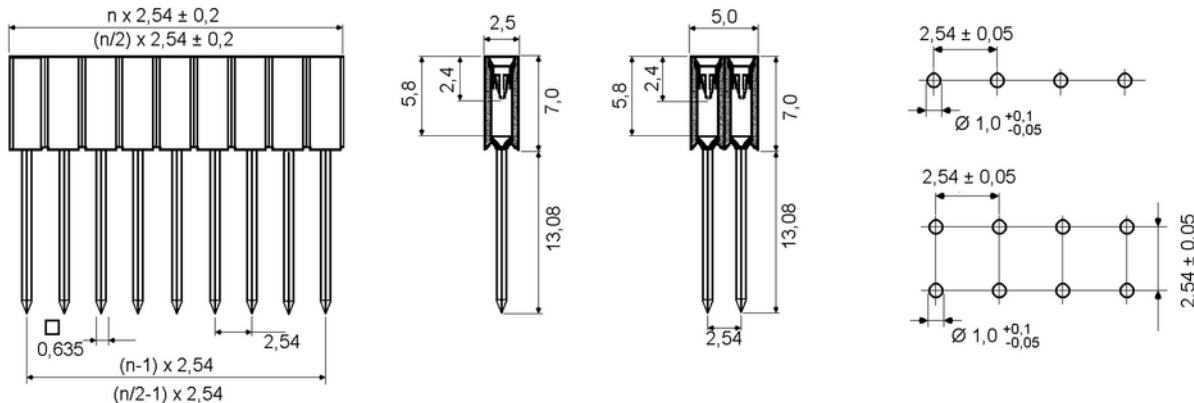

Kontaktstifte nicht ausgerichtet / Pins not adjusted

Ausgerichtet auf Anfrage / Adjusted on request.

Series	Contacts*	Rows*	Sleeve Plating	Clip Plating*
315	004	2	50	00
	002-050 Einreihig <i>Single row</i> 004-100 Zweireihig <i>Double row</i>	1 Einreihig <i>Single row</i> 2 Zweireihig <i>Double row</i>	50 Hülse verzinkt <i>Tin plated sleeve</i>	00 Feder vergoldet <i>Gold plated clip</i> 10 Feder 0,25µm Gold (Option) <i>0.25µm gold plated clip (Option)</i> 30 Feder 0,75µm Gold <i>0.75µm gold plated clip</i> 50 Feder verzinkt <i>Tin plated clip</i>

* Dies ist ein **Bestellbeispiel** -
bitte durch Ihre Spezifikationen ersetzen.
* This is an **order example** -
please replace by your specifications.

Empfehlungen für das Wellenlötverfahren

Recommendations for Wave Soldering

Die Bauteile sollten bei einer Lötbadtemperatur von 260°C in max. 5 Sekunden verlötet werden.
Items should be soldered at a solder temperature of 260°C in 5 seconds max.

Empfohlenes Wellenlötprofil:
Recommended wave soldering profile:



Reflow-Lötempfehlung

Reflow Soldering Recommendation

Die Bauteile sollten gemäß folgendem Temperatur-Profil in Anlehnung an die IPC/JEDEC J-STD-020C für bleifreies Löten im Reflow-Verfahren verarbeitet werden (Maximalwerte).

Profileigenschaft	Kennwert
Temperatur Minimum T_{Smin}	150°C
Temperatur Maximum T_{Smax}	200°C
Dauer $T_{Smin} - T_{Smax}$	60-180s
Temperatur Lötbereich T_L	217°C
Verweildauer oberhalb T_L	60-180s
Ramp-Up Rate $T_{Smax} - T_P$	max. 3°C / s
Höchsttemperatur T_P	260°C ±5
Dauer Höchsttemperatur	20-40s
Ramp-Down Rate $T_{Pmax} - T_{Smin}$	6°C / s
Dauer 25°C - Höchsttemperatur T_P	Max. 8 min

Items should be soldered according to IPC/JEDEC J-STD-020C temperature profile for leadfree reflow soldering (maximum values).

Profile Feature	Key Values
Minimum Temperature T_{Smin}	150°C
Maximum Temperatur T_{Smax}	200°C
Duration $T_{Smin} - T_{Smax}$	60-180s
Soldering Range Temperature T_L	217°C
Duration above T_L	60-180s
Ramp-Up Rate $T_{Smax} - T_P$	max. 3°C / s
Peak Temperature T_P	260°C ±5
Duration Peak Temperature	20-40s
Ramp-Down Rate $T_{Pmax} - T_{Smin}$	6°C / s
Duration 25°C - Peak Temp. T_P	Max. 8min

