

Power-Terminal RM 5,00mm, Buchsenkontakte, gewinkelt Power-Terminal 5.00mm Pitch, Female, Right-angled

Technische Daten / Technical Data

Isolierkörper	Thermoplast, UL94 V-0
Insulator	Thermoplastic, UL94 V-0
Kontaktmaterial	Kupferlegierung
Contact Material	Copper alloy
Kontaktoberfläche	Lt. Oberflächenoptionen, über Ni
Contact Surface	Acc. to plating options, over Ni
Lötbarkeit	IEC 60512-12A
Solderability	IEC 60512-12A
Nennspannung	600 V AC / 848 V DC
Voltage Rating	600 V AC / 848 V DC
Nennstrom	24,7 A
Current Rating	24.7 A
Temperaturbereich	-55° ... +105° C (Sn plating)
Temperature Range	-55° ... +125° C (Au plating)
	-55° ... +105° C (Sn plating)
	-55° ... +125° C (Au plating)
Verarbeitung	260°C für 10s
Processing	260°C for 10s

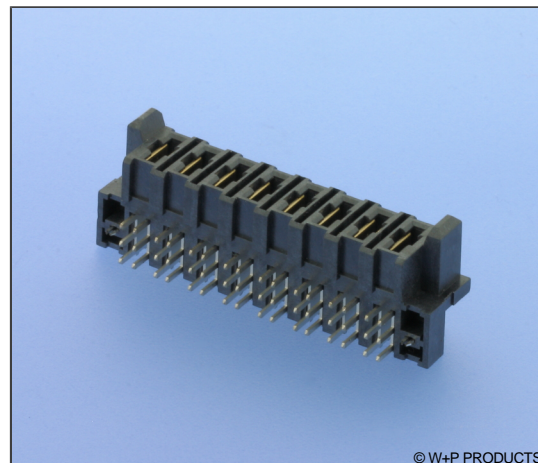

© W+P PRODUCTS

Gegenstecker / Mating Connectors : 452, 453

W/Screw Down

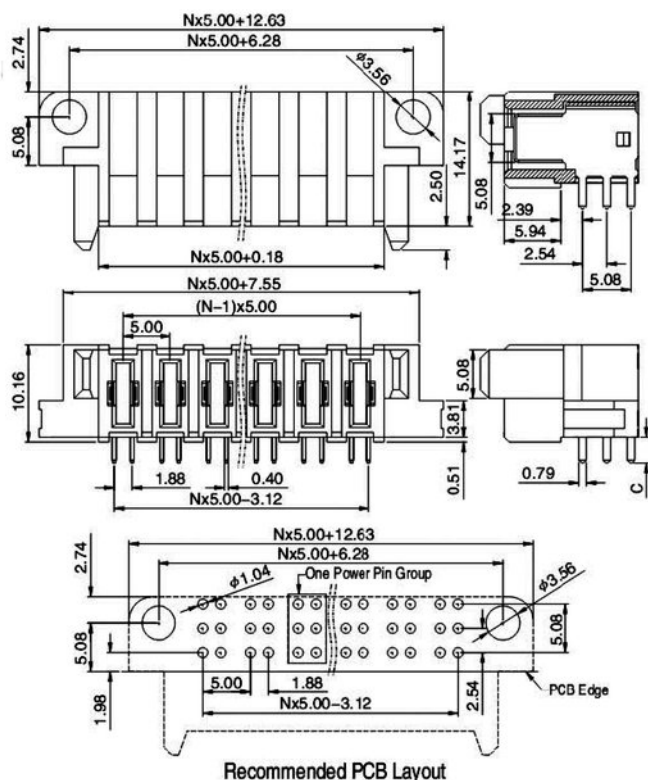

W/Locking Clip

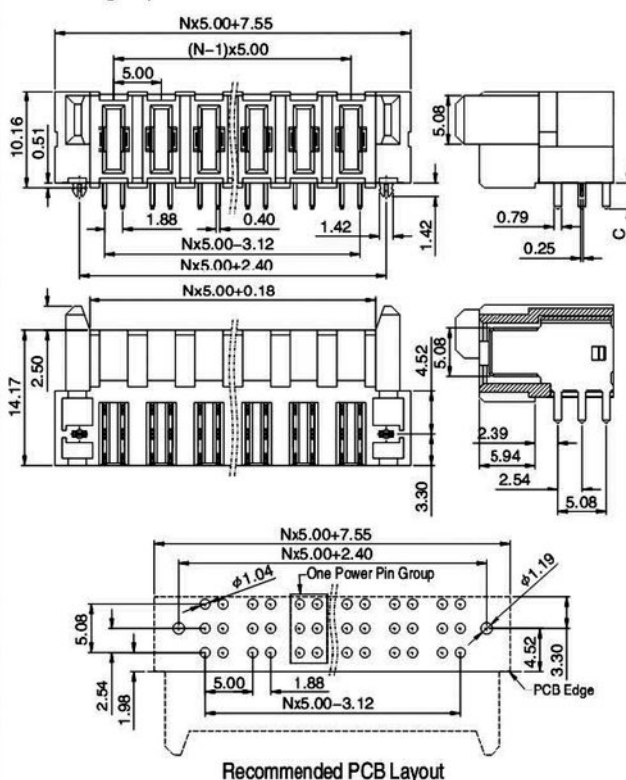

Series	Contacts*	Terminal Type*	Plating*	Locating Option*	Packaging*
451	06	21	00	20	ST
	02 03 04 06 08	20 C=2.72mm 21 C=3.52mm 22 C=4.32mm	00 Au flash 50 Sn 60 Sel. Au/Sn 610 Sel. Au 10µ"/Sn	20 Locking Clips 30 Screw Down	ST TRAY

* Dies ist ein **Bestellbeispiel** - bitte durch Ihre Spezifikationen ersetzen.
* This is an **order example** - please replace by your specifications.

Lieferformen / Packaging Options:

ST In Stangen / In tubes
TRAY Auf Tray / On tray

Informationen zum Reflow-Lötverfahren

Reflow Soldering Information

Reflow-Lötempfehlung

Reflow Soldering Recommendation

Die Bauteile sollten gemäß folgendem Temperatur-Profil in Anlehnung an die IPC/JEDEC J-STD-020C für bleifreies Löten im Reflow-Verfahren verarbeitet werden (Maximalwerte).

Profileigenschaft	Kennwert
Temperatur Minimum T_{Smin}	150°C
Temperatur Maximum T_{Smax}	200°C
Dauer $T_{Smin} - T_{Smax}$	60-180s
Temperatur Lötbereich T_L	217°C
Verweildauer oberhalb T_L	60-180s
Ramp-Up Rate $T_{Smax} - T_P$	max. 3°C / s
Höchsttemperatur T_P	260°C ±5
Dauer Höchsttemperatur	20-40s
Ramp-Down Rate $T_{Pmax} - T_{Smin}$	6°C / s
Dauer 25°C - Höchsttemperatur T_P	Max. 8 min

Items should be soldered according to IPC/JEDEC J-STD-020C temperature profile for leadfree reflow soldering (maximum values).

Profile Feature	Key Values
Minimum Temperature T_{Smin}	150°C
Maximum Temperatur T_{Smax}	200°C
Duration $T_{Smin} - T_{Smax}$	60-180s
Soldering Range Temperature T_L	217°C
Duration above T_L	60-180s
Ramp-Up Rate $T_{Smax} - T_P$	max. 3°C / s
Peak Temperature T_P	260°C ±5
Duration Peak Temperature	20-40s
Ramp-Down Rate $T_{Pmax} - T_{Smin}$	6°C / s
Duration 25°C - Peak Temp. T_P	Max. 8min

