

## Crimp-Rast-Verbinder RM 2,00mm, gewinkelt, Einlöt-Kontakte Crimp Connectors, 2.00mm Pitch, Right-Angled, Solder-In Terminal

### Technische Daten / Technical Data

Isolierkörper <i>Insulator</i>	Thermoplastischer Kunststoff, nach UL94 V-0 <i>Thermoplastic, rated UL94 V-0</i>
Kontaktmaterial <i>Contact Material</i>	Kupferlegierung <i>Copper alloy</i>
Aderquerschnitt <i>Applicable wire Gauge</i>	AWG 30 ~ 26 <i>AWG 30 ~ 26</i>
Durchgangswiderstand <i>Contact Resistance</i>	< 20mΩ <i>&lt; 20mΩ</i>
Isolationswiderstand <i>Insulation Resistance</i>	> 1000MΩ <i>&gt; 1000MΩ</i>
Spannungsfestigkeit <i>Test Voltage</i>	800V <sub>AC</sub> <i>800V<sub>AC</sub></i>
Nennspannung <i>Voltage Rating</i>	250V <sub>AC</sub> <i>250V<sub>AC</sub></i>
Nennstrom <i>Current Rating</i>	1A <i>1A</i>
Temperaturbereich <i>Temperature Range</i>	-25°C ... +85°C <i>-25°C ... +85°C</i>
Verarbeitung <i>Processing</i>	Wellenlötverfahren <i>Wave soldering</i>

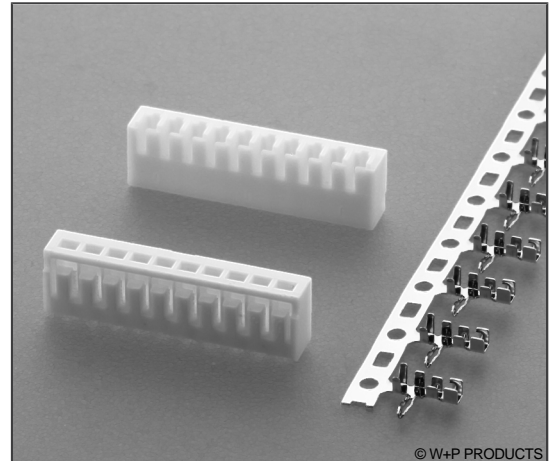

© W+P PRODUCTS

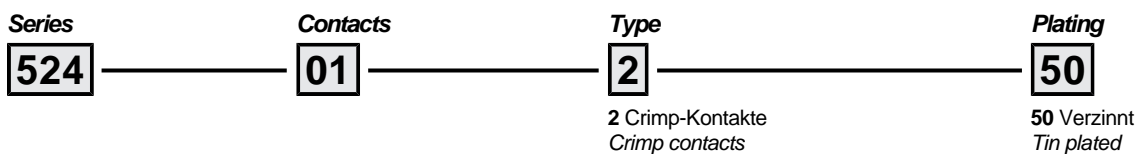
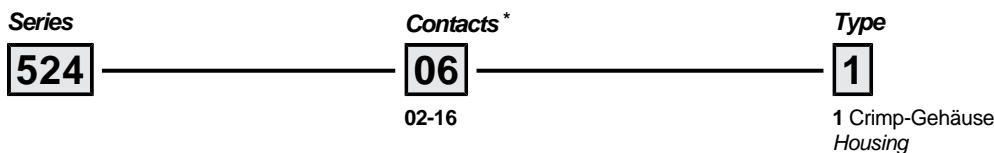
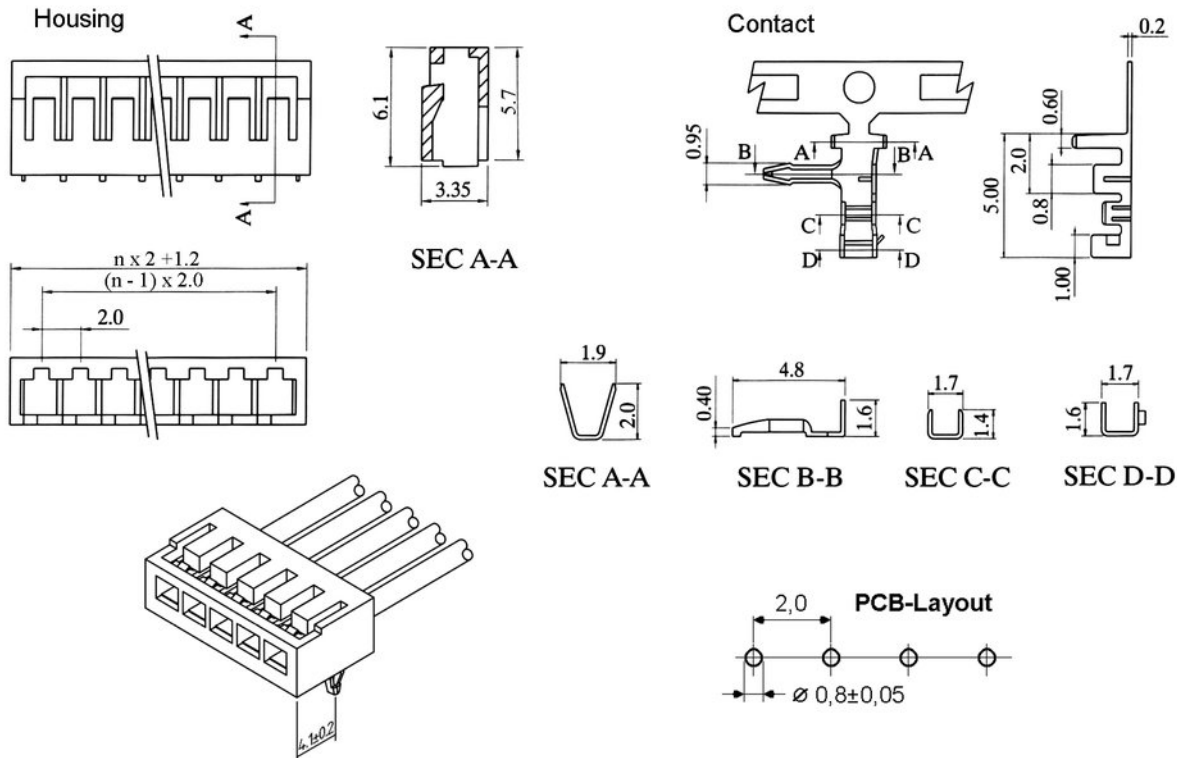

\* Dies ist ein **Bestellbeispiel** -  
bitte durch Ihre Spezifikationen ersetzen.  
\* This is an **order example** -  
please replace by your specifications.

### Empfehlungen für das Wellenlötverfahren

#### Recommendations for Wave Soldering

Die Bauteile sollten bei einer Lötbadtemperatur von 260°C in max. 5 Sekunden verlötet werden.  
*Items should be soldered at a solder temperature of 260°C in 5 seconds max.*

Empfohlenes Wellenlötprofil:  
*Recommended wave soldering profile:*

