

Sandwich-Stiftleisten RM 1,00mm, 1-/2-reihig

Dual Body Pin Headers, 1.00mm Pitch, Single/Double Row

Technische Daten / Technical Data

Isolierkörper	Thermoplastischer Kunststoff, nach UL94 V-0
Insulator	Thermoplastic, rated UL94 V-0
Kontaktmaterial	Vierkantstift 0,30mm, Kupferlegierung
Contact Material	0.30mm square pin, copper alloy
Kontaktoberfläche	Lt. Oberflächenoptionen, über Ni (1,3 ... 2,5µm)
Contact Surface	Acc. to options (see below), over Ni (1.3 ... 2.5µm)
Durchgangswiderstand	< 20mΩ
Contact Resistance	< 20mΩ
Isolationswiderstand	> 500MΩ
Insulation Resistance	> 500MΩ
Spannungsfestigkeit	500V _{AC}
Test Voltage	500V _{AC}
Nennstrom	1A
Current Rating	1A
Temperaturbereich	-40°C ... +105°C
Temperature Range	-40°C ... +105°C
Verarbeitung	Wellen- oder Reflow-Lötverfahren
Processing	Wave or reflow soldering

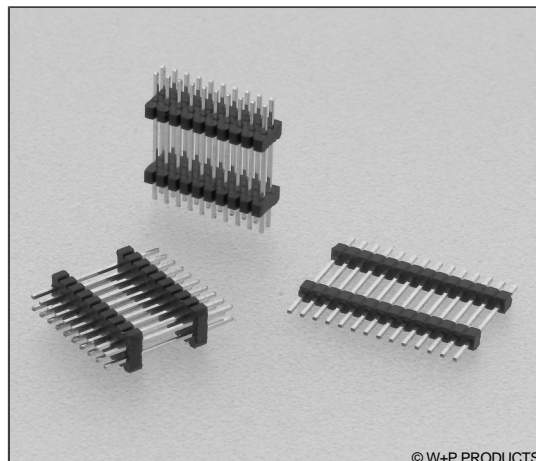

© W+P PRODUCTS

Passende Buchsenleisten:
Compatible Female Headers:
7091

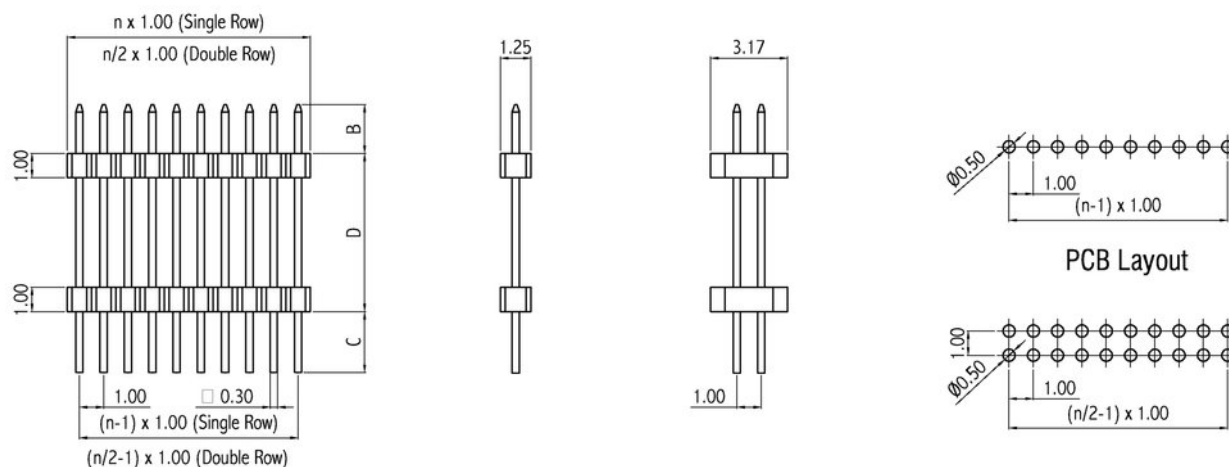

Series	Contacts*	Rows*	Dimensions*	Plating*
722	020	2	10	50
	001-050 Einreihig Single row 002-100 Zweireihig Double row	1 Einreihig Single row 2 Zweireihig Double row	10 B=2,00 C=2,50 D=6,50mm A [mm] Kundenspezifisch (max. 23,0mm) Customer-specific (max. 23,0mm)	00 Vergoldet Gold plated 50 Verzinkt Tin plated 60 Sel. Au/Sn Duplex plating

* Dies ist ein **Bestellbeispiel** -
bitte durch Ihre Spezifikationen ersetzen.
* This is an **order example** -
please replace by your specifications.

Empfehlungen für das Wellenlötverfahren

Recommendations for Wave Soldering

Die Bauteile sollten bei einer Lötbadtemperatur von 260°C in max. 5 Sekunden verlötet werden.
Items should be soldered at a solder temperature of 260°C in 5 seconds max.

Empfohlenes Wellenlötprofil:
Recommended wave soldering profile:



Reflow-Lötempfehlung

Reflow Soldering Recommendation

Die Bauteile sollten gemäß folgendem Temperatur-Profil in Anlehnung an die IPC/JEDEC J-STD-020C für bleifreies Löten im Reflow-Verfahren verarbeitet werden (Maximalwerte).

Profileigenschaft	Kennwert
Temperatur Minimum T_{Smin}	150°C
Temperatur Maximum T_{Smax}	200°C
Dauer $T_{Smin} - T_{Smax}$	60-180s
Temperatur Lötbereich T_L	217°C
Verweildauer oberhalb T_L	60-180s
Ramp-Up Rate $T_{Smax} - T_P$	max. 3°C / s
Höchsttemperatur T_P	260°C ±5
Dauer Höchsttemperatur	20-40s
Ramp-Down Rate $T_{Pmax} - T_{Smin}$	6°C / s
Dauer 25°C - Höchsttemperatur T_P	Max. 8 min

Items should be soldered according to IPC/JEDEC J-STD-020C temperature profile for leadfree reflow soldering (maximum values).

Profile Feature	Key Values
Minimum Temperature T_{Smin}	150°C
Maximum Temperatur T_{Smax}	200°C
Duration $T_{Smin} - T_{Smax}$	60-180s
Soldering Range Temperature T_L	217°C
Duration above T_L	60-180s
Ramp-Up Rate $T_{Smax} - T_P$	max. 3°C / s
Peak Temperature T_P	260°C ±5
Duration Peak Temperature	20-40s
Ramp-Down Rate $T_{Pmax} - T_{Smin}$	6°C / s
Duration 25°C - Peak Temp. T_P	Max. 8min

