

SMT-Micro-USB Verbinder, Typen B & AB, Buchsen liegend SMT Micro-USB Connectors, Types B & AB, Jacks Horizontal

Technische Daten / Technical Data

Isolierkörper	Thermoplastischer Kunststoff, nach UL94 V-0
Insulator	Thermoplastic, rated UL94 V-0
Kontaktmaterial	Kupferlegierung
Contact Material	Copper alloy
Lötbarkeit	IEC 60512-12A
Solderability	IEC 60512-12A
Durchgangswiderstand	< 30mΩ
Contact Resistance	< 30mΩ
Isolationswiderstand	> 1000MΩ
Insulation Resistance	> 1000MΩ
Spannungsfestigkeit	500V _{AC}
Test Voltage	500V _{AC}
Nennspannung	30V _{RMS}
Voltage Rating	30V _{RMS}
Nennstrom	1,5A bei 25°C
Current Rating	1,5A at 25°C
Temperaturbereich	-55°C ... +85°C
Temperature Range	-55°C ... +85°C
Verarbeitung	Reflow-Lötverfahren
Processing	Reflow soldering

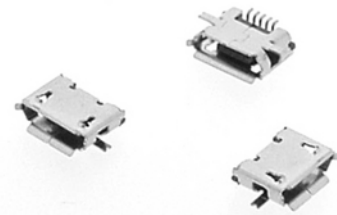

© W+P PRODUCTS

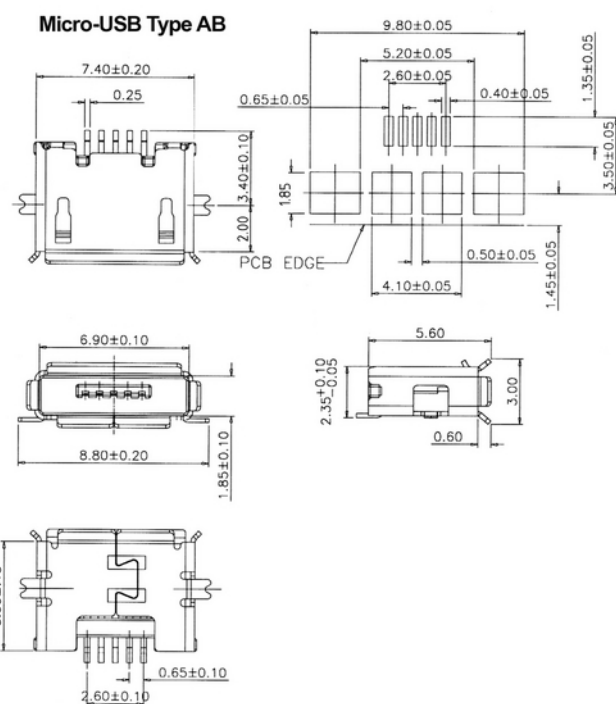
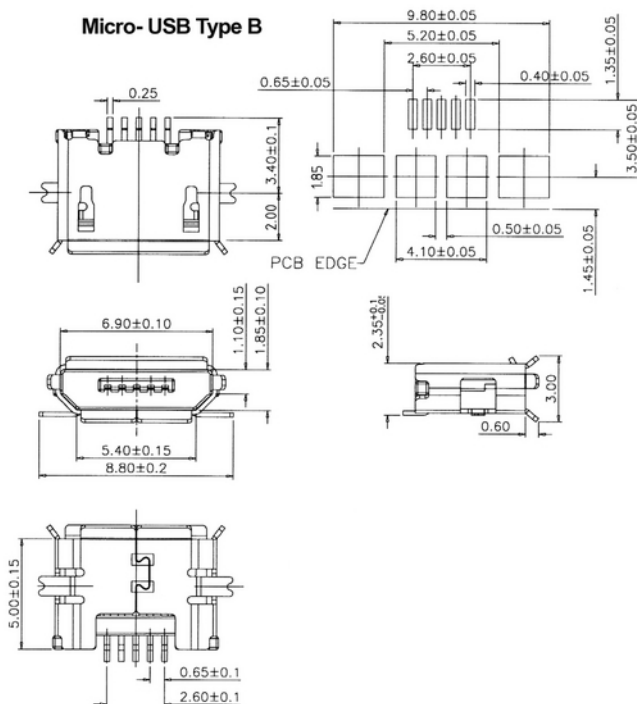

Serie	Type*	Layout	Colour	Plating	Packing
8270	2	2	10	80	TR
	2 Type B Female 3 Type AB Female	2 Liegend Horizontal	10 Schwarz Black	80 Sel. Au 0,75µm/Sn (USB 2.0)	TR Tape & Reel Tape & Reel

* Dies ist ein **Bestellbeispiel** - bitte durch Ihre Spezifikationen ersetzen.
* This is an **order example** - please replace by your specifications.

TEL +49 5223 98507-0
FAX +49 5223 98507-50

W+P PRODUCTS

E-MAIL sales@wpro.com
WEBSITE www.wpro.com

Informationen zum Reflow-Lötverfahren

Reflow Soldering Information

Reflow-Lötempfehlung

Reflow Soldering Recommendation

Die Bauteile sollten gemäß folgendem Temperatur-Profil in Anlehnung an die IPC/JEDEC J-STD-020C für bleifreies Löten im Reflow-Verfahren verarbeitet werden (Maximalwerte).

Profileigenschaft	Kennwert
Temperatur Minimum T_{Smin}	150°C
Temperatur Maximum T_{Smax}	200°C
Dauer $T_{Smin} - T_{Smax}$	60-180s
Temperatur Lötbereich T_L	217°C
Verweildauer oberhalb T_L	60-180s
Ramp-Up Rate $T_{Smax} - T_P$	max. 3°C / s
Höchsttemperatur T_P	260°C ±5
Dauer Höchsttemperatur	20-40s
Ramp-Down Rate $T_{Pmax} - T_{Smin}$	6°C / s
Dauer 25°C - Höchsttemperatur T_P	Max. 8 min

Items should be soldered according to IPC/JEDEC J-STD-020C temperature profile for leadfree reflow soldering (maximum values).

Profile Feature	Key Values
Minimum Temperature T_{Smin}	150°C
Maximum Temperatur T_{Smax}	200°C
Duration $T_{Smin} - T_{Smax}$	60-180s
Soldering Range Temperature T_L	217°C
Duration above T_L	60-180s
Ramp-Up Rate $T_{Smax} - T_P$	max. 3°C / s
Peak Temperature T_P	260°C ±5
Duration Peak Temperature	20-40s
Ramp-Down Rate $T_{Pmax} - T_{Smin}$	6°C / s
Duration 25°C - Peak Temp. T_P	Max. 8min

