

Technische Daten / Technical Data

Isolierkörper <i>Insulator</i>	Thermoplast, nach UL94 V-0 <i>Thermoplastic, rated UL94 V-0</i>
Kontaktmaterial <i>Contact Material</i>	Kupferlegierung <i>Copper alloy</i>
Kontaktoberfläche <i>Contact Surface</i>	Lt. Oberflächenoptionen, über Ni <i>Acc. to plating options, over Ni</i>
Durchgangswiderstand <i>Contact Resistance</i>	< 25mΩ
Isolationswiderstand <i>Insulation Resistance</i>	> 1000MΩ
Spannungsfestigkeit <i>Test Voltage</i>	500V _{AC}
Temperaturbereich <i>Temperature Range</i>	-55°C ... +125°C
Verarbeitung <i>Processing</i>	Reflow-Lötverfahren <i>Reflow soldering</i>

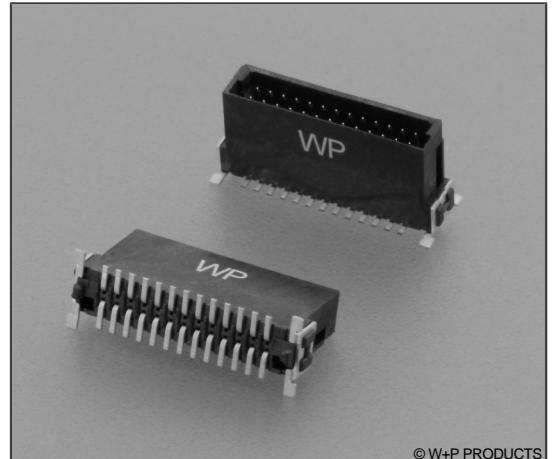

© W+P PRODUCTS

nnectors:
J12 9013

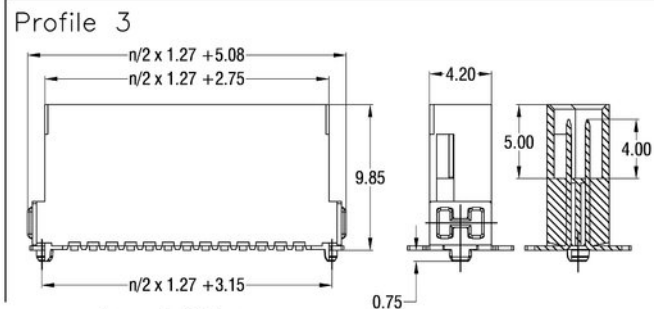
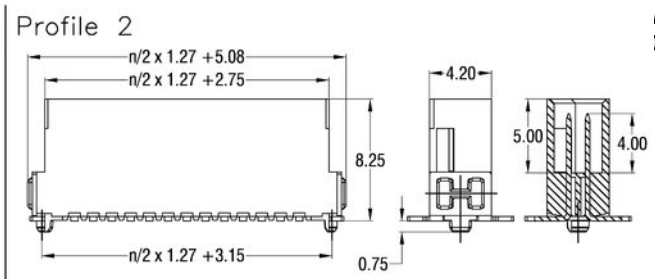
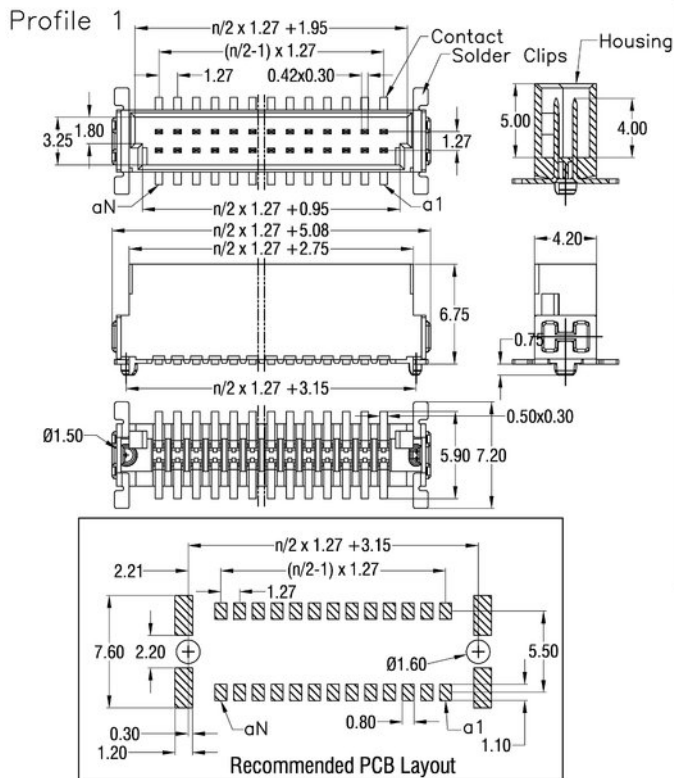

Current Rating :

No of pos	Ambient Temp		
	20°C	70°C	100°C
12	1.6A	1.1A	0.7A
26	1.3A	0.9A	0.6A
50	1.1A	0.8A	0.5A
68	1.0A	0.8A	0.5A
80	1.0A	0.8A	0.5A

Series	Contacts*	Profile*	Plating*	Packaging*
9015	50 12 26 50 68 80 Weitere Polzahlen auf Anfrage More contact options on request	1 1 H=6.75mm 2 H=8.25mm 3 H=9.85mm	80 60 Sel. Au flash / Sn 80 Sel. Au 30µ" / Sn 908 Sel. 8u"PdNi / 2u"Au 928 Sel. 28u"PdNi / 2u"Au	PPTR ST TR PPST PPTR

Übersicht über Bauhöhen in den technischen Informationen
Mating Height Chart under technical information

Lieferformen / Packaging Options:

- ST In Stangen ohne Pick&Place-Pads / In tubes w/o Pick&Place-Pads
- TR Tape & Reel ohne PP-Pads / Tape & Reel w/o PP-Pads
- PPST In Stangen mit PP-Pads / In tubes with PP-Pads
- PPTR Tape & Reel mit PP-Pads / Tape & Reel with PP-Pads

* Dies ist ein **Bestellbeispiel** - bitte durch Ihre Spezifikationen ersetzen.
* This is an **order example** - please replace by your specifications.

9012 9013 9014 9015

Übersicht über die erreichbaren Bauhöhen Chart of Attainable Mating Heights

9013 + 9015

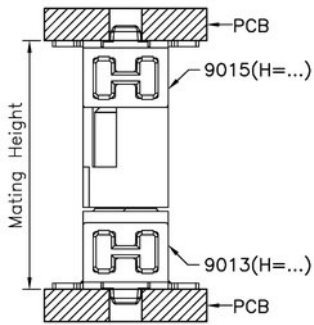

Mating Height		9015		
		H=6.75mm	H=8.25mm	H=9.85mm
9013	H=6.25mm	8.0 - 9.5	9.5 - 11.0	11. - 12.6
	H=9.05mm	10.8 - 12.3	12.3 - 13.8	13.9 - 15.4
	H=13.65mm	15.4 - 16.9	16.9 - 18.4	18.5 - 20.0

9012 + 9015

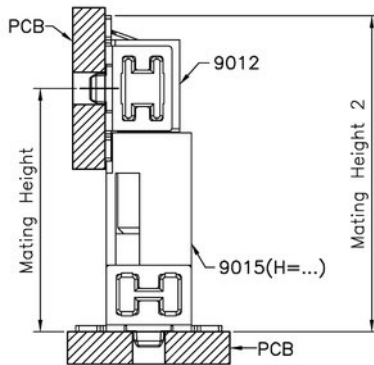

Mating Heights		9015		
		H=6.75mm	H=8.25mm	H=9.85mm
9012	8.95 - 10.45	10.45 - 11.95	12.05 - 13.55	
	12.55 - 14.05	14.05 - 15.55	15.65 - 17.15	

9013 + 9014

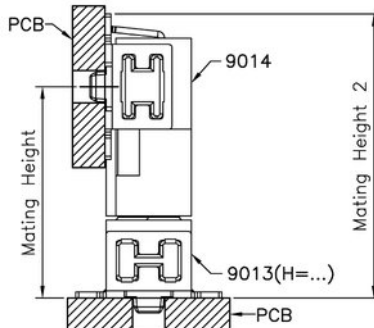

Mating Heights		9013		
		H=6.25mm	H=9.05mm	H=13.65mm
9014	7.65 - 9.15	10.45 - 11.95	15.05 - 16.55	
	11.25 - 12.75	14.05 - 15.55	18.65 - 20.15	

9012 + 9014

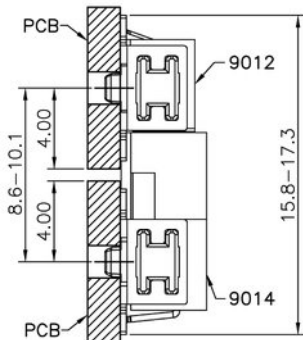

Reflow-Lötempfehlung

Reflow Soldering Recommendation

Die Bauteile sollten gemäß folgendem Temperatur-Profil in Anlehnung an die IPC/JEDEC J-STD-020C für bleifreies Löten im Reflow-Verfahren verarbeitet werden (Maximalwerte).

Profileigenschaft	Kennwert
Temperatur Minimum T_{Smin}	150°C
Temperatur Maximum T_{Smax}	200°C
Dauer $T_{Smin} - T_{Smax}$	60-180s
Temperatur Lötbereich T_L	217°C
Verweildauer oberhalb T_L	60-180s
Ramp-Up Rate $T_{Smax} - T_P$	max. 3°C / s
Höchsttemperatur T_P	260°C ±5
Dauer Höchsttemperatur	20-40s
Ramp-Down Rate $T_{Pmax} - T_{Smin}$	6°C / s
Dauer 25°C - Höchsttemperatur T_P	Max. 8 min

Items should be soldered according to IPC/JEDEC J-STD-020C temperature profile for leadfree reflow soldering (maximum values).

Profile Feature	Key Values
Minimum Temperature T_{Smin}	150°C
Maximum Temperatur T_{Smax}	200°C
Duration $T_{Smin} - T_{Smax}$	60-180s
Soldering Range Temperature T_L	217°C
Duration above T_L	60-180s
Ramp-Up Rate $T_{Smax} - T_P$	max. 3°C / s
Peak Temperature T_P	260°C ±5
Duration Peak Temperature	20-40s
Ramp-Down Rate $T_{Pmax} - T_{Smin}$	6°C / s
Duration 25°C - Peak Temp. T_P	Max. 8min

