

Copying of this document and giving it to others and the use or communication of the contents thereof are forbidden without express authority. Offenders are liable to the payment of damages. All rights are reserved in the event of the grant of a patent or the registration of a utility model or design.

**SPECIFICATIONS**

Rated Current:3.0AMP  
 Contact Resistance:20mΩ Max  
 Withstand Voltage:1000V AC/DC  
 Insulation Resistance:1000MΩ Min  
 Operation Temperature:-40°C to +105°C

Contact Material:Brass  
 Contact Plating:Au Over Ni  
 Insulator Material:Polyester(UL94V-0)  
 Standard: PA6T  
 Max.Processing Temp: 230°C for 30-60 seconds  
 (260°C for 10 seconds)

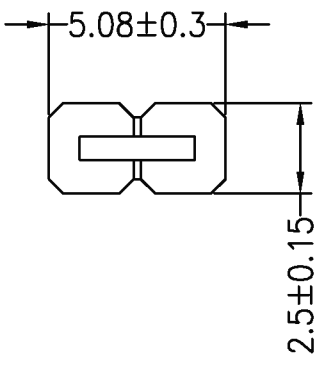

Recommended P.C.B Layout(Top Side)  
(PCB BOARD TOLERANCE±0.05)

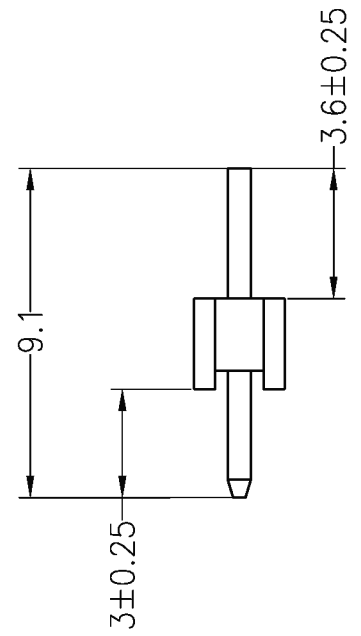
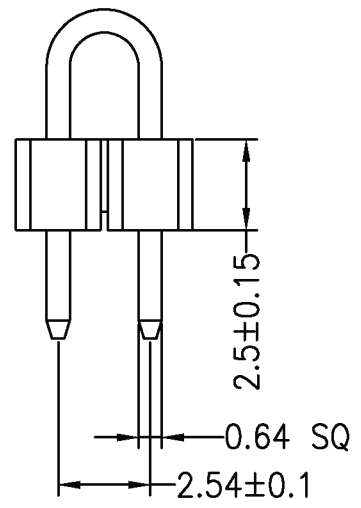
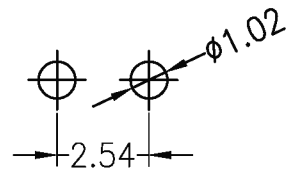

Weitergabe sowie Vervielfältigung dieses Urhebers, Verwertung und Mitteilung ihres Inhaltes ist nicht gestattet, soweit nicht ausdrücklich zugestanden. Zuwiderhandlungen verpflichten zu Schadenersatz. Alle Rechte für den Fall der Patenterteilung oder Gebrauchsmuster-Eintragung vorbehalten.

X.X	±0.30
X.XX	±0.20
X.XXX	±0.10
Angle	±3°
DIM	TOL

Zust./Ver.	Änderung / Revision	Datum	Name	Potzahl/No. of Contacts		Maßstab/Scale		
				Best.-Schlüssel s. Katalogangaben / For Order Code pls refer to Cat.				
				Erstellt/Drawn	mb	2014-04-23	Benennung / Title: <b>943-U-Haken-00</b> Alternative Artikel-Nr. / Product Key: <b>943-U-Haken-00/S</b>	Blatt/Sheet:
				Geprüft/Checked	me	2014-04-23		
				Freigegeben/Approved	ps	2014-04-23		
				<b>W+P PRODUCTS</b> Daimlerstr. 29-33 D-32257 Bünde Tel. +49 52 23 / 9 85 07-0 Fax +49 52 23 / 9 85 07-50 e-mail: info@wppro.com				van/of:
				Art. entspr. RoHS / RoHS compl. 2002/95/EC		Datei/File:		
				Urspr/Src:		Ers/Rpl:		Ers.v./Rpl.by: