

XTAL

HC-49/U-2H

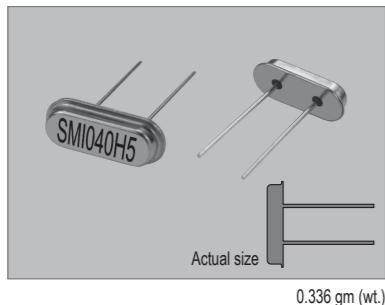

HC-49/U-3H

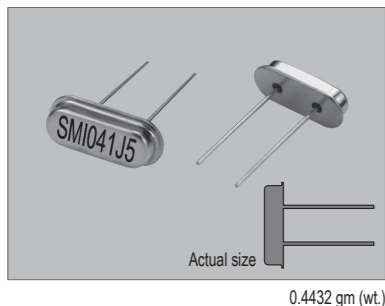

HC-49/U-4H

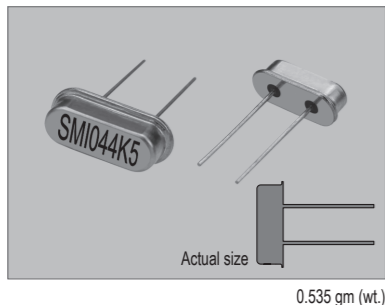

STANDARD SPECIFICATIONS

Item	Specifications
Holder type	HC-49/U-2H, HC-49/U-3H & HC-49/U-4H
Frequency range	3.579545 MHz to 61.000 MHz
Frequency tolerance	±50 ppm at +25°C ±3°C
Temperature stability (referred to +25°C)	±50 ppm over -20°C to +70°C
Load capacitance (CL)	16 pF, Typical
Shunt capacitance (C0)	5 pF max.
Drive level (P)	100 µW max. (10 µW for testing)
Aging	±5 ppm max. at +25°C ±3°C per year
Cut / Oscillation mode	AT-Cut / Fundamental / 3.579545 MHz to 40.000 MHz
	BT-Cut / Fundamental / 28.636363 MHz to 50.000 MHz
	AT-Cut / 3rd overtone / 26.690000 MHz to 61.000 MHz

PART NUMBERING GUIDE

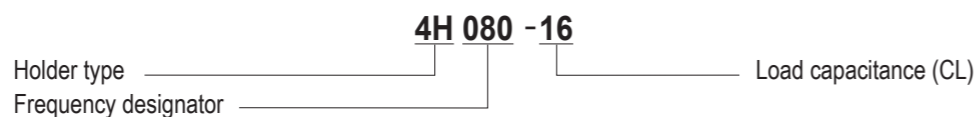

Example

SMI Part No.	Holder	Circuit Calibration Condition	Frequency
2H221-18	2H = HC-49/U-2H	Parallel resonance CL = 18 pF	221 = 22.1184 MHz
3H450S	3H = HC-49/U-3H	S = Series resonance	450 = 45.000 MHz
4H080-16	4H = HC-49/U-4H	Parallel resonance CL = 16 pF	080 = 8.000 MHz

HOLDER DATA

Item	Holder	HC-49/U-2H	HC-49/U-3H	HC-49/U-4H
Cover		Metal	Metal	Metal
Base		Metal	Metal	Metal
Sealing		Resistance	Resistance	Resistance
Terminal lead		Alloy (FeNiCo)	Alloy (FeNiCo)	Alloy (FeNiCo)
Terminal plating		SnCu	SnCu	SnCu
RoHS		Compliant (Pb-free)	Compliant (Pb-free)	Compliant (Pb-free)

HC-49/U-4H

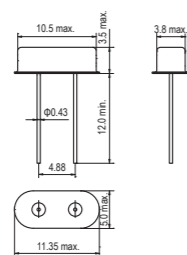

HC-49/U-2H

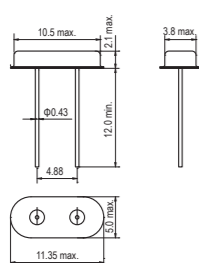

HC-49/U-3H

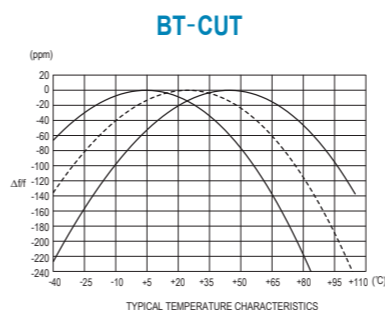
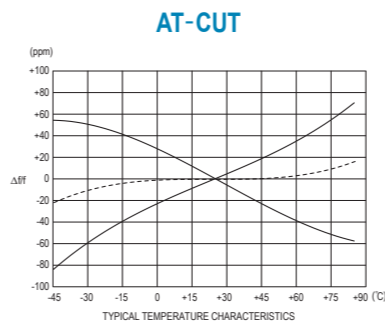
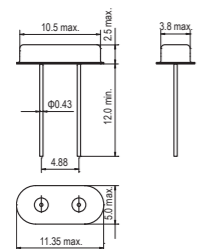

HC-49/U-2H, 3H & 4H STANDARD FREQUENCIES

Frequency MHz	Frequency Designator	Max. Equivalent Series Resistance (Ω) ESR	Frequency MHz	Frequency Designator	Max. Equivalent Series Resistance (Ω) ESR	Frequency MHz	Frequency Designator	Max. Equivalent Series Resistance (Ω) ESR
3.579545	035	200	13.410000	1341	50	30.800000	308	40
3.580000	0358	200	13.500000	135	50	31.708000	317	40
3.648000	0364	200	13.544375	1354	50	32.000000	320	40
3.686400	0368	200	13.560000	1356	50	32.110000	321	40
3.840000	0384	200	13.567200	135672	50	32.768000	32768	40
3.932160	039	200	13.577000	13577	50	33.000000	330	40
4.000000	040	150	14.000000	140	50	33.177600	3317	40
4.032000	0403	150	14.316000	14316	50	33.333000	33333	40
4.096000	0409	150	14.318180	143	50	33.868800	338	40
4.194304	041	150	14.400000	144	50	35.468950	354	40
4.433000	0443	150	14.580000	1458	50	36.000000	360	40
4.433619	044	150	14.745600	147	50	36.864000	368	40
4.500000	045	150	15.000000	150	50	37.745000	377	40
4.608000	046	150	15.360000	153	50	38.000000	380	40
4.800000	048	150	15.980000	1598	50	40.000000	400	40
4.906250	04906	150	16.000000	160	50	40.685000	4068	40 (BT-Cut)
4.915200	049	150	16.384000	163	50	40.750000	4075	40 (BT-Cut)
5.000000	050	120	16.588000	1658	50	43.391670	4339	40 (BT-Cut)
5.089062	0508	120	16.934400	1693	50	45.000000	450	40 (BT-Cut)
5.333000	05333	120	17.700000	177	50	48.000000	480	40 (BT-Cut)
5.333333	053	120	17.734470	1773447	50	49.860000	4986	40 (BT-Cut)
5.699623	056	120	17.734475	1773	50	50.000000	500	40 (BT-Cut)
6.000000	060	100	18.000000	180	50	50.032000	50032	40 (BT-Cut)
6.144000	061	100	18.432000	184	50	50.803200	508	40 (BT-Cut)
6.176000	0617	100	19.069929	19069929	50	54.000000	540	40 (BT-Cut)
6.480000	0648	100	19.200000	192	50	61.000000	610	40 (BT-Cut)
6.745800	0674	100	19.260000	1926	50			
6.764300	067643	100	19.312000	193	50			
6.764380	0676	100	19.440000	194	50			
6.776170	0677	100	19.608000	19608	50			
6.783600	0678	100	19.660800	196	50			
7.372800	073	80	19.680000	1968	50			
7.500000	075	80	20.000000	200	40			
7.680000	0768	80	20.250000	2025	40			
8.000000	080	80	20.250800	202508	40			
8.190000	0819	80	20.476000	20476	40			
8.192000	08192	80	20.480000	2048	40			
8.400000	084	80	20.945000	20945	40			
9.000000	090	60	22.118400	221	40			
9.031600	0903	60	22.425000	22425	40			
9.216000	092	60	22.525000	22525	40			
9.600000	096	60	22.787500	227875	40			
9.690900	096909	60	22.887500	22887	40			
9.690990	0969099	60	23.000000	230	40			
9.718750	0971	60	23.600000	236	40			
9.830400	098	60	23.975000	23975	40			
9.843750	0984	60	24.000000	240	40			
10.000000	100	60	24.576000	245	40			
10.111000	101	60	25.000000	250	40			
10.202000	102	60	26.500000	265	40			
10.245000	10245	60	26.540000	2654	40			
10.368000	103	60	26.800000	268	40			
10.781200	1078	60	26.998435	26998	40			
11.000000	110	60	27.000000	270	40			
11.059200	1105	60	27.145000	27145	40			
11.290000	1129	60	27.586000	2758	40			
12.000000	120	60	28.000000	280	40			
12.270000	1227	60	28.224000	282	40			
12.288000	122	60	28.636000	28636	40			
12.296000	1229	60	28.636300	286363	40			
12.334375	12334	60	28.636363	2863	40			
13.000000	130	50	28.920000	2892	40			
13.234370	1323	50	29.000000	290	40			
13.248000	132	50	29.491200	294	40			
13.401560	13401	50	29.498900	294989	40			
13.406250	13406	50	30.000000	300	40			

XTAL

CLK OSC

VCXO

TCXO

OCXO

MCF