

SMT-Mini-Taster, 4,2x3,3mm, stehend, Bauhöhe 3,4mm SMT Mini Tactile Switches, 4.2x3.3mm, vertical, 3.4mm Profile

Technische Daten / Technical Data

Gehäuse/Abdeckung/Hebel	Thermoplast/Stahl/Thermoplast, UL-94 HB
Case/Cover/Actuator	Thermoplastic/Steel/Thermoplastic, UL-94 HB
Kontaktmaterial	Messing
Contact Material	Brass
Kontaktbelastbarkeit	50mA, 12V _{DC}
Contact Rating	50mA, 12V _{DC}
Kontaktoberfläche	Versilbert
Contact Surface	Silver plated
Oberfläche Lötanschluss	Versilbert
Plating Solder Side	Silver plated
Lötbarkeit	IEC 60512-12A
Solderability	IEC 60512-12A
Durchgangswiderstand	< 100mΩ im Auslieferungszustand
Contact Resistance	< 100mΩ at initial state
Isolationswiderstand	> 100MΩ im Auslieferungszustand
Insulation Resistance	> 100MΩ at initial state
Spannungsfestigkeit	250V _{AC}
Test Voltage	250V _{AC}
Temperaturbereich	-20°C ... +70°C
Temperature Range	-20°C ... +70°C
Mechanische Lebensdauer	min. 100 000 Schaltvorgänge
Mechanical Life	min. 100 000 operations
Verarbeitung	Reflow-Lötverfahren
Processing	Reflow soldering

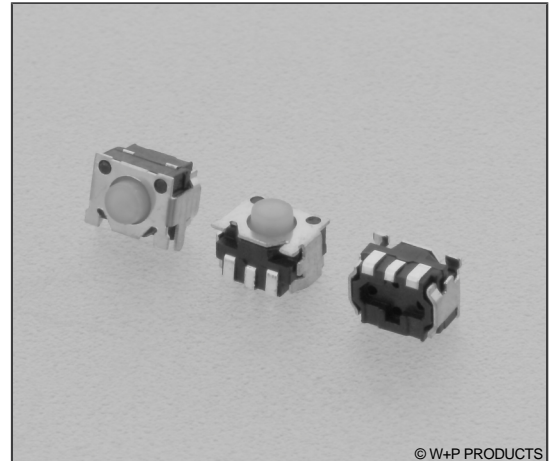

© W+P PRODUCTS

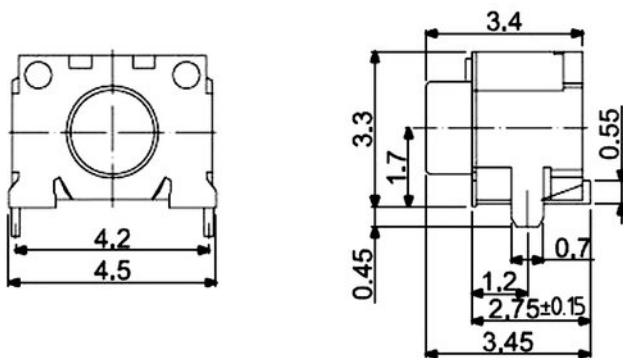

P.C.B. Layout

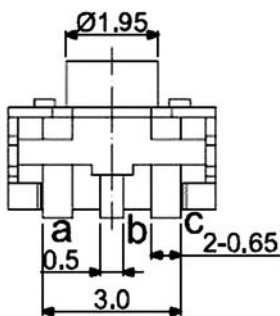
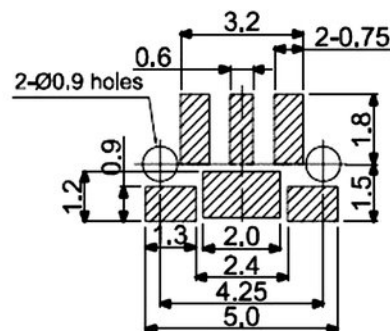

CIRCUIT DIAGRAM

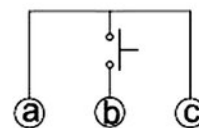

Series	Height	Force	Locating Pegs	Packaging*
515	1 1 H=3.40mm	30 30 160g±30	10 10 Mit Pos.hilfen With loc. pegs	TR 00 TR

* Dies ist ein **Bestellbeispiel** - bitte durch Ihre Spezifikationen ersetzen.
* This is an **order example** - please replace by your specifications.

Lieferformen / Packaging Options:
00 Schüttgut / Bulk goods
TR Tape & Reel (Option) / Tape & Reel (Option)

Informationen zum kurzen Reflow-Lötverfahren

Fast Profile Reflow Soldering Information

Reflow-Löttempfegung für kurze Lötzeiten

Reflow Soldering Recommendation for shorter peak times

Die Bauteile sollten gemäß folgendem Temperatur-Profil in Anlehnung an die IPC/JEDEC J-STD-020C für bleifreies Löten im Reflow-Verfahren verarbeitet werden (Maximalwerte).

Profileigenschaft	Kennwert
Temperatur Minimum T_{Smin}	150°C
Temperatur Maximum T_{Smax}	200°C
Dauer $T_{Smin} - T_{Smax}$	120-150s
Temperatur Lötbereich T_L	230°C
Verweildauer oberhalb T_L	60s max.
Ramp-Up Rate $T_{Smax} - T_P$	max. 1,5°C / s
Höchsttemperatur T_P	260°C max.
Dauer Höchsttemperatur	5-10s
Ramp-Down Rate $T_{Pmax} - T_{Smin}$	3°C / s
Dauer 25°C - Höchsttemperatur T_P	Max. 4,5min

Items should be soldered according to IPC/JEDEC J-STD-020C temperature profile for leadfree reflow soldering (maximum values).

Profile Feature	Key Values
Minimum Temperature T_{Smin}	150°C
Maximum Temperatur T_{Smax}	200°C
Duration $T_{Smin} - T_{Smax}$	120-150s
Soldering Range Temperature T_L	230°C
Duration above T_L	60s max.
Ramp-Up Rate $T_{Smax} - T_P$	max. 1.5°C / s
Peak Temperature T_P	260°C max.
Duration Peak Temperature	5-10s
Ramp-Down Rate $T_{Pmax} - T_{Smin}$	3°C / s
Duration 25°C - Peak Temp. T_P	Max. 4.5min

